

# LES EKOVOORES

SYSTÈME CIRCULAIRE, LOCAL, RÉSILIENT POUR ALIMENTER LA VILLE

# SYSTÈME LINÉAIRE D'ALIMENTATION

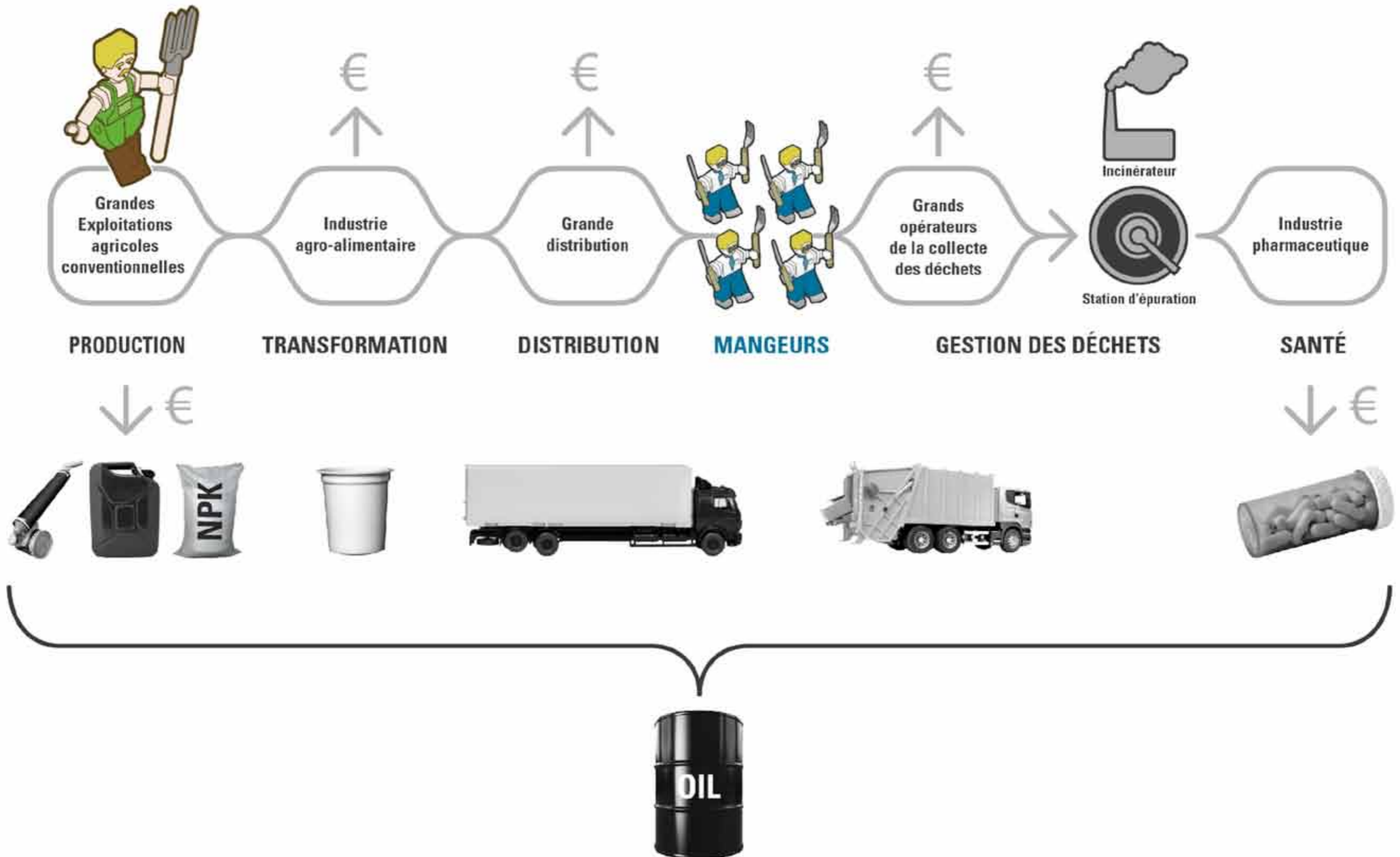

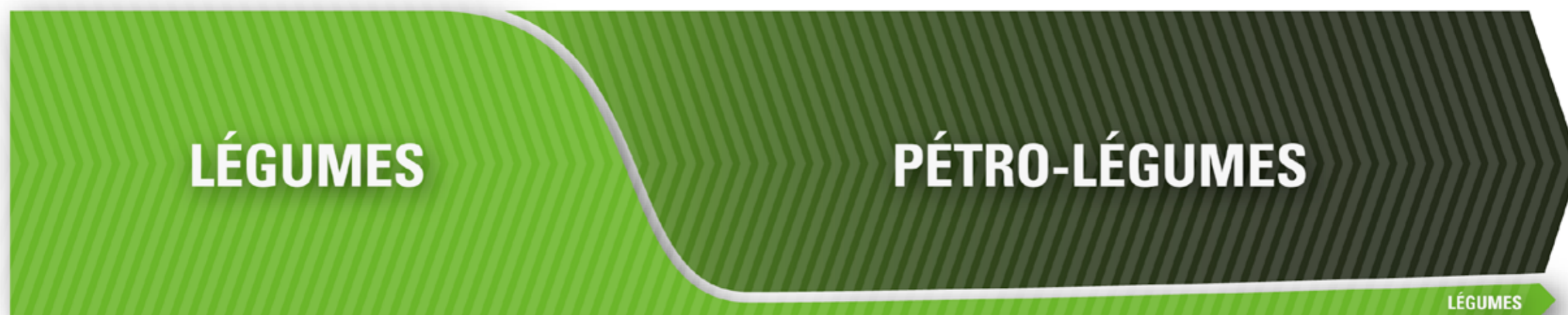
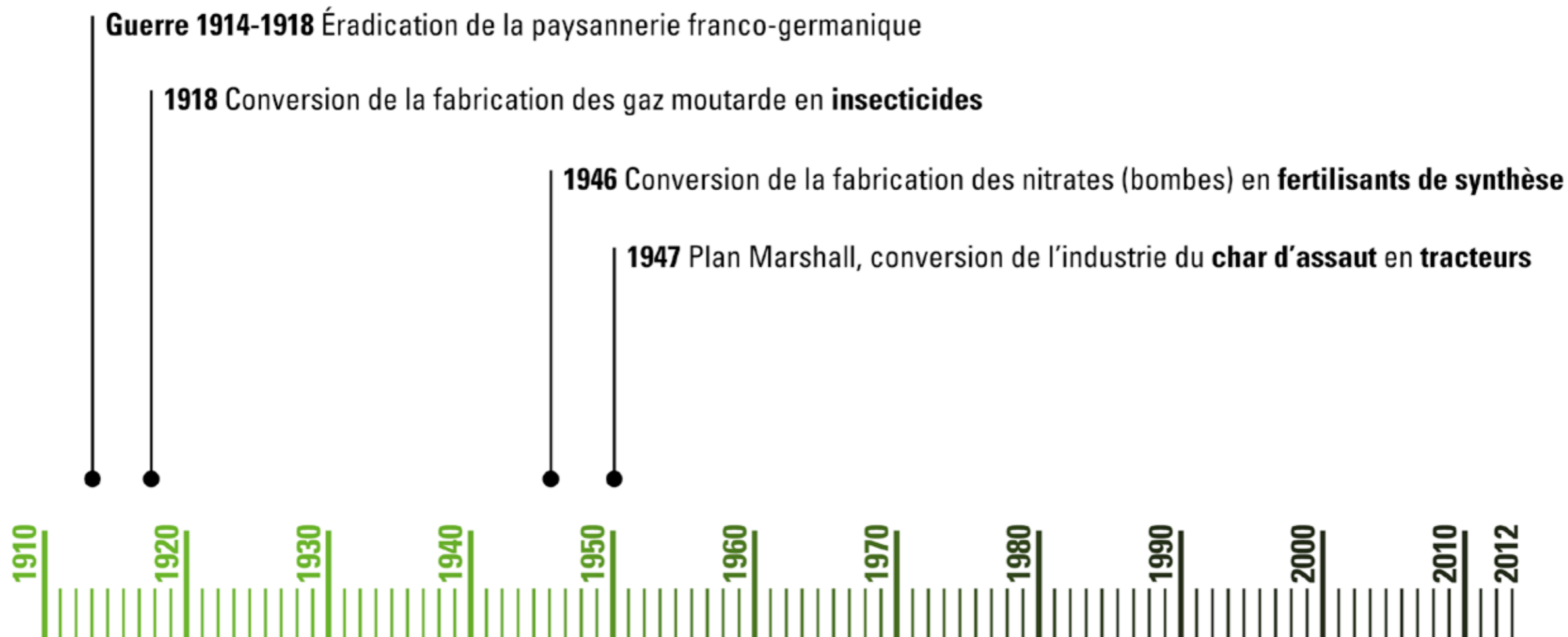

**RÉVOLUTION VERTE  
INCITATION À LA PÉTRO-AGRICULTURE**

$$1354/31=45\text{ans}$$

Réserves prouvées en milliards de barils

Production annuelle en milliards de barils/an

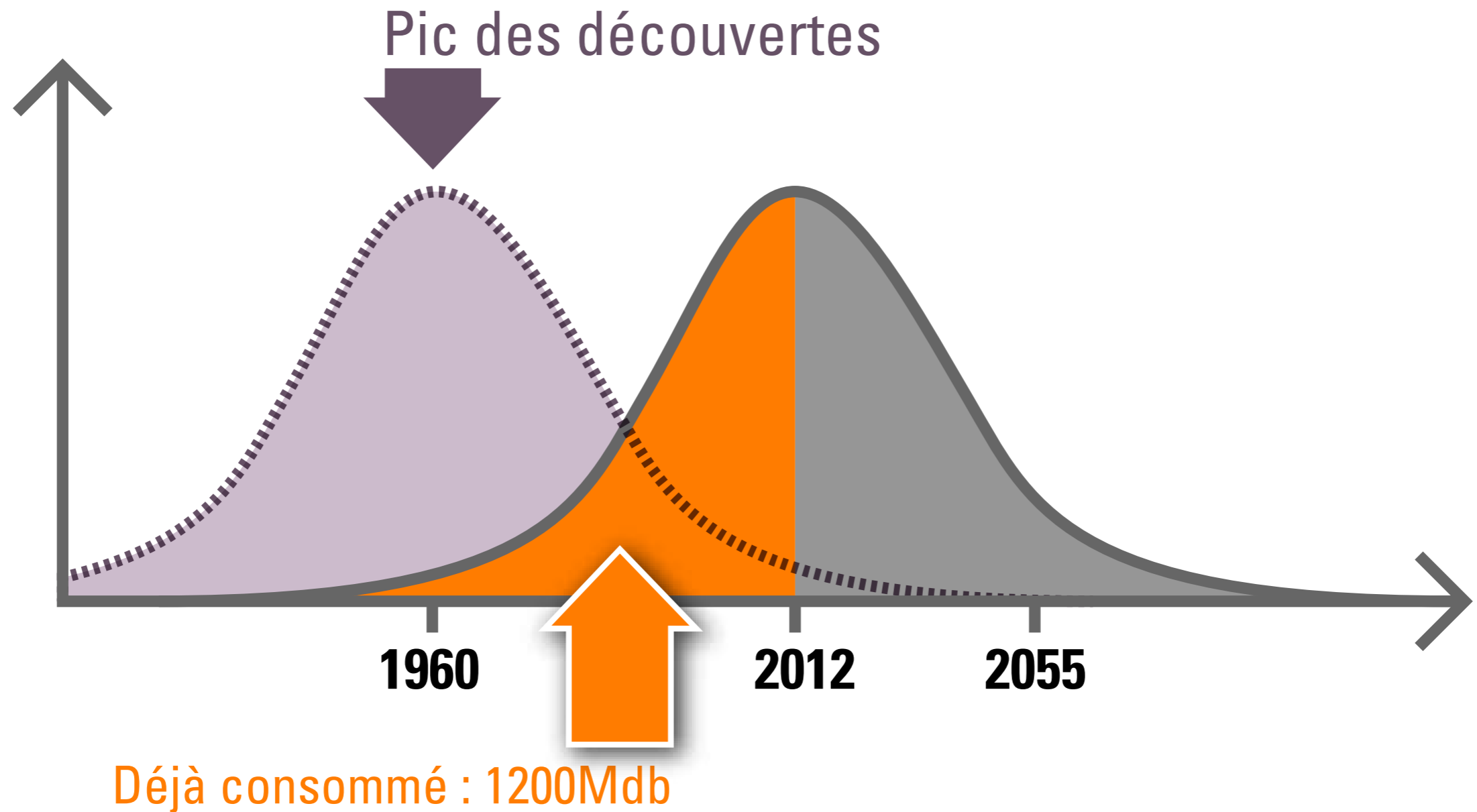

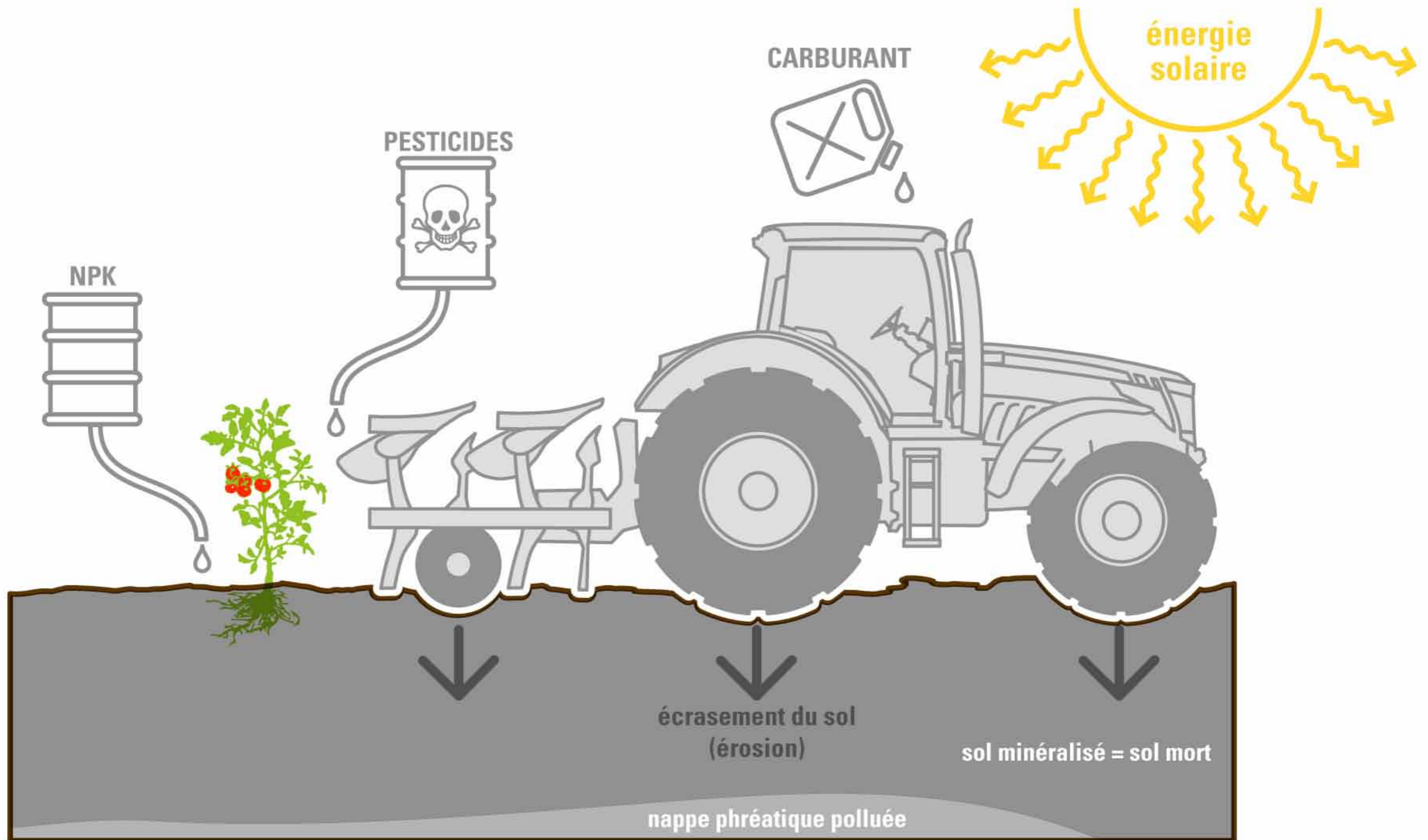

semence hybride F1



MONOCULTURE / RÉCOLTE COURTE  
**AGRICULTURE CONVENTIONNELLE**

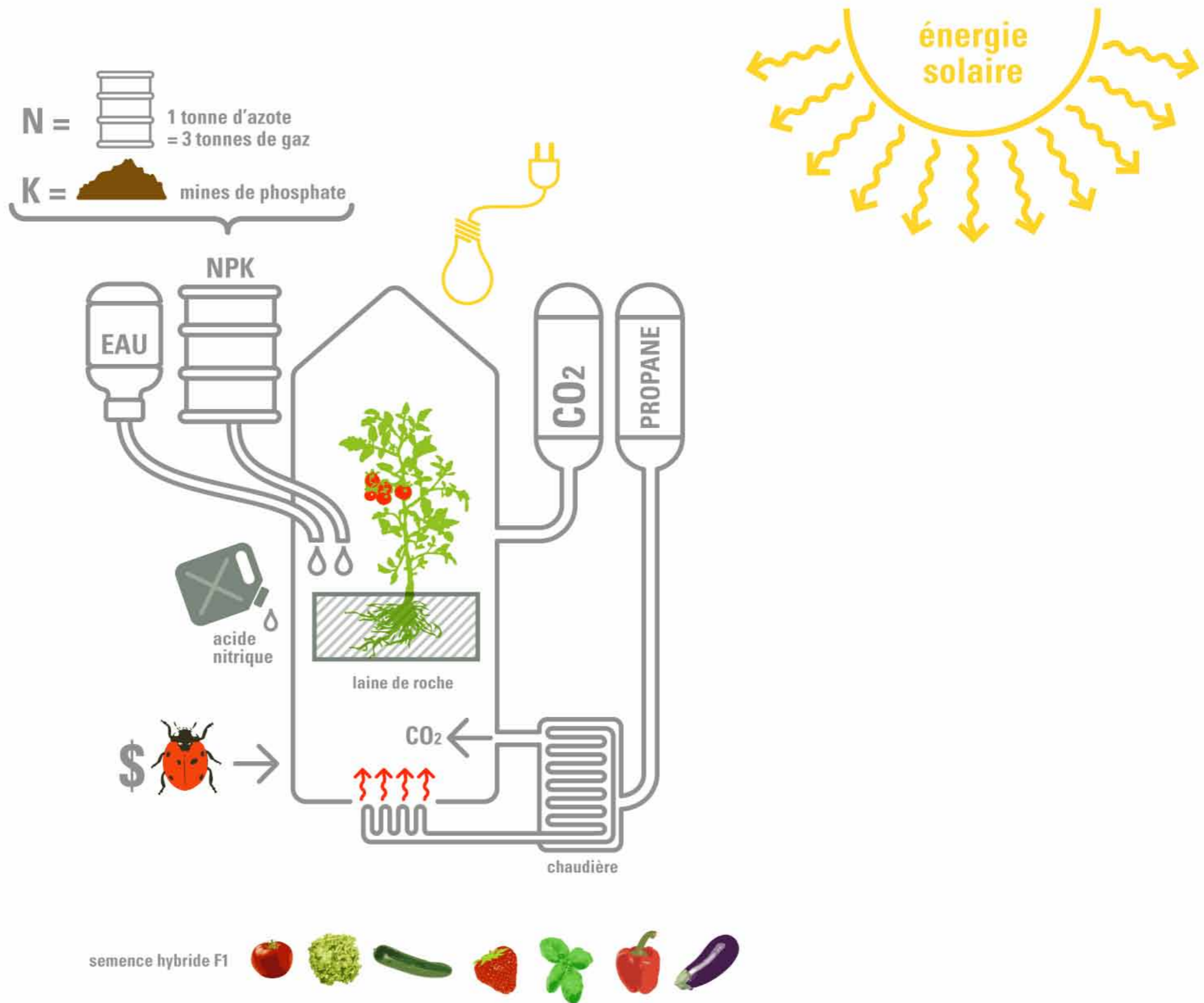

RÉCOLTE LONGUE (février-novembre)  
**AGRICULTURE HORS-SOL**

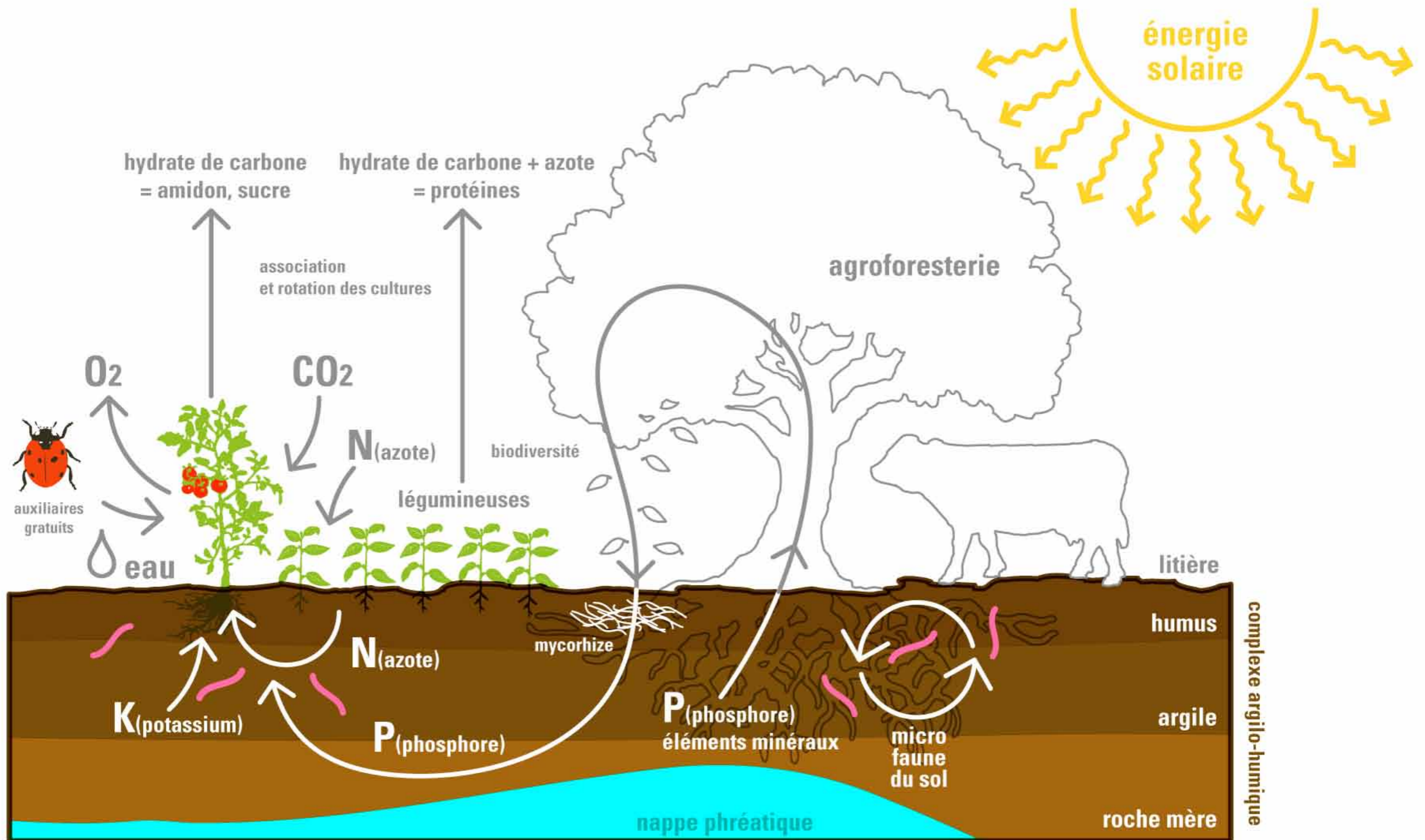

**POLYCULTURE / RÉCOLTE COURTE (juin-septembre)**  
**AGROÉCOLOGIE**

# AGROÉCOLOGIE

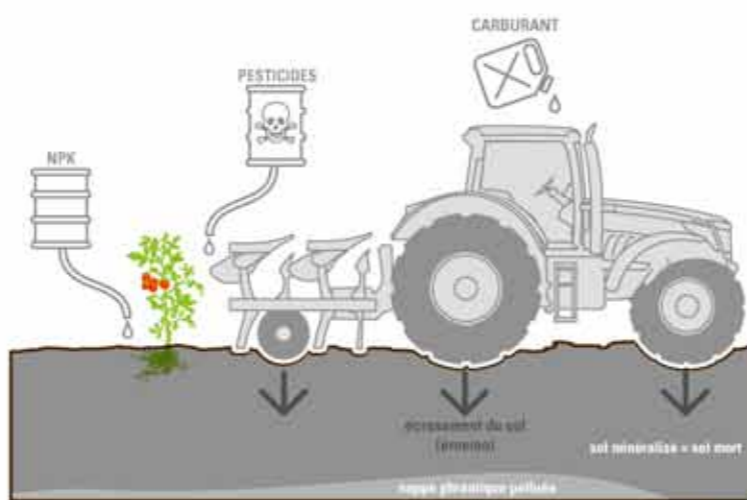
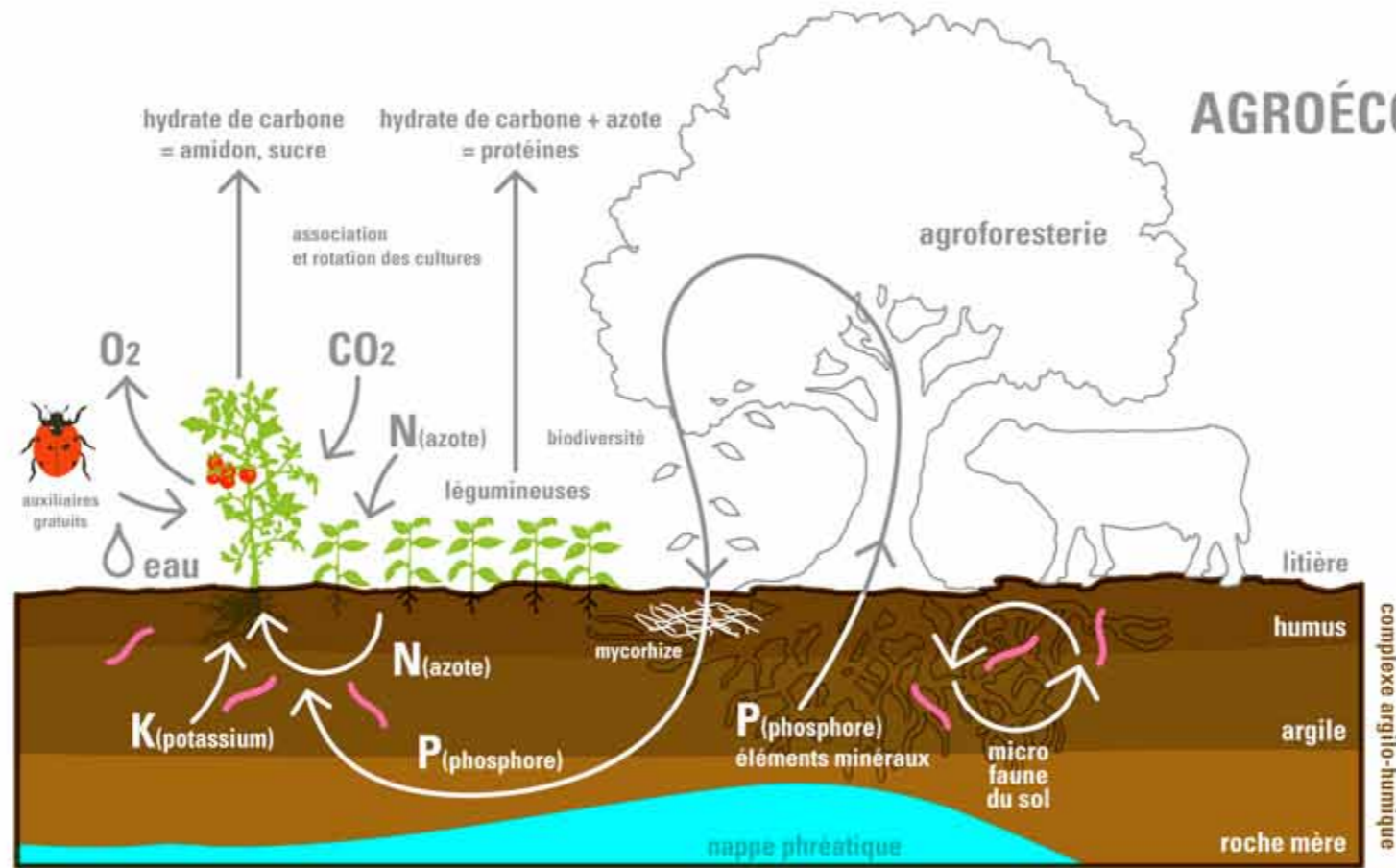

AGRICULTURE CONVENTIONNELLE

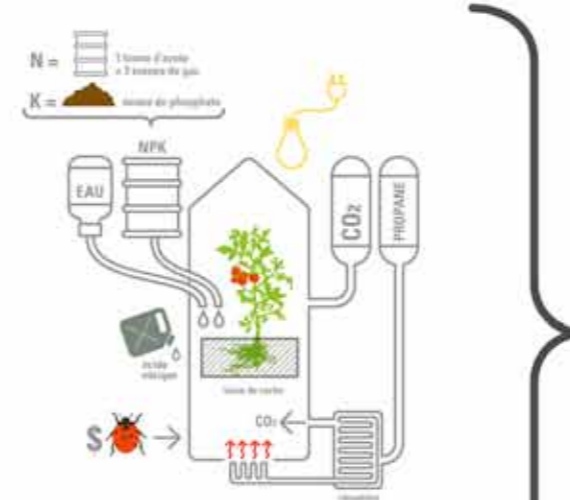

AGRICULTURE HORS-SOL





# ALIMENTER LA VILLE DE NANTES AVEC UNE AGRICULTURE Saine, LOCALE, SANS PÉTROLE

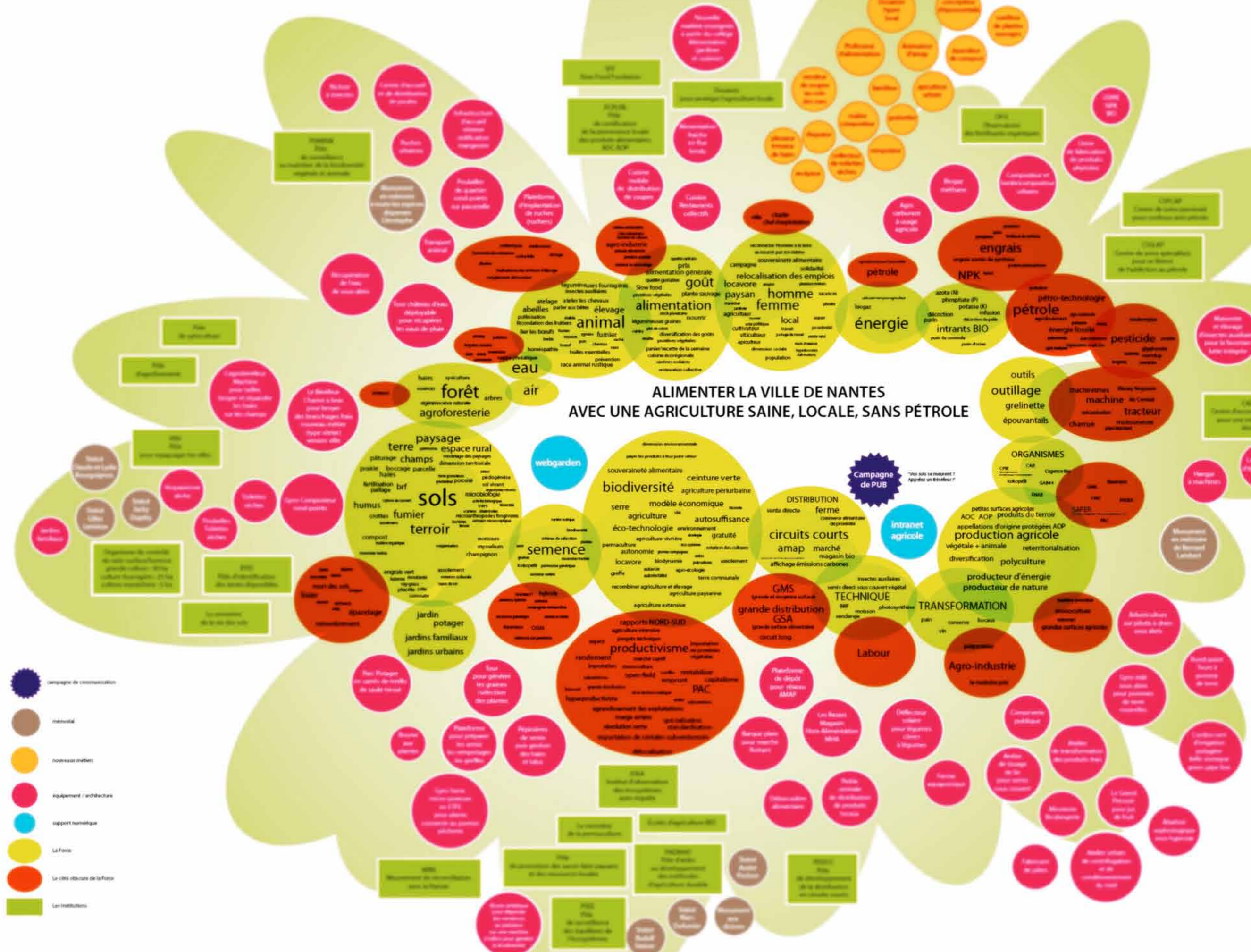

- campagne de communication
- identité
- nouveaux métiers
- équipement / architecture
- support numérique
- La Forêt
- Le côté obscure de la Forêt
- Les Institutions



AGRICULTURE URBAINE  
DETROIT



GRADING POWER  
E



TEMPELHOF GARTEN  
BERLIN - ALLEMAGNE



ROOF FARMING - BROOKLYN GRANGE  
BROOKLYN



PRINZESSINNENGÄRTEN  
BERLIN - ALLEMAGNE



AUX FRATERNITÉS OUVRIÈRES  
MOUSCRON - BELGIQUE



AGRICULTURE URBAINE



HORTILLONNAGE  
AMIENS



TAQWA COMMUNITY FARM  
NEW YORK - USA



STATIONS GOURMANDES  
VILLE DE NANTES



VERGERS PUBLICS  
LAUSANNE



PERMACULTURE  
FERME DU BEC HELLOUIN



MIEL URBAIN - HK HONEY  
HONG KONG



AMAP / 3% DE CIRCUITS-COURTS  
DEPUIS 2001  
FRANCE



CSA / COMMUNAUTY SUPPORTED AGRICULTURE  
DEPUIS 1985  
USA



EIKEI / 25% DE CIRCUITS-COURTS  
DEPUIS 1971  
JAPON



SLOW FOOD  
ITALIE



CEINTURE ALIMENT-TERRE  
LIÈGE



TRINKWASSERSHUTZGEBIET  
REISACH GOTZING THALHAM  
ALLEMAGNE



MARCHÉ SUR L'EAU  
PARIS - BASSIN DE LA VILLETTE

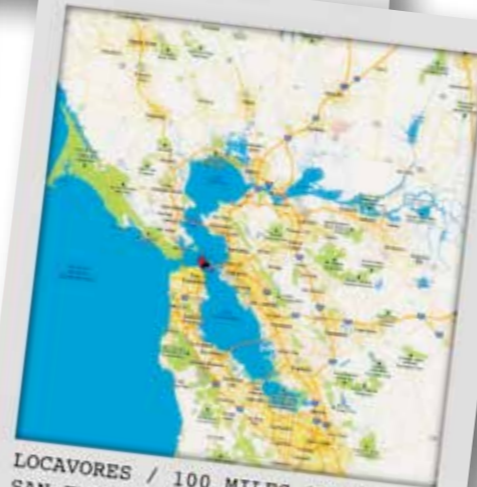

LOCAVORES / 100 MILES-160 KM  
SAN FRANCISCO



TRANSITION TOWN  
TOTNES



GUERRILLA GARDENING  
LONDRES



COMPOSTRI  
NANTES



COLLECTE DES DÉCHETS AUX TRAIIS  
HAZEBROUCK



TRANSHUMANCE URBAINE  
ASSOCIATION CLINAMEN  
PARIS - FRANCE



CHAMPIGNONNIÈRE URBAINE U-FARM  
PARIS - FRANCE



CONSERVERIE COLLECTIVE  
COULON



PRESSOIR ARTISANALE  
REDON - FRANCE



TOILETTES SÈCHES - HUMUS 44  
NANTES



2 POULES OU UN LOMBRICOMPOSTEUR  
MOUSCRON



NICHOIR À INSECTES  
VAULOT&DYÈVRE / PARIS

# SYSTÈME CIRCULAIRE, LOCAL, RÉSILIENT POUR ALIMENTER LA VILLE

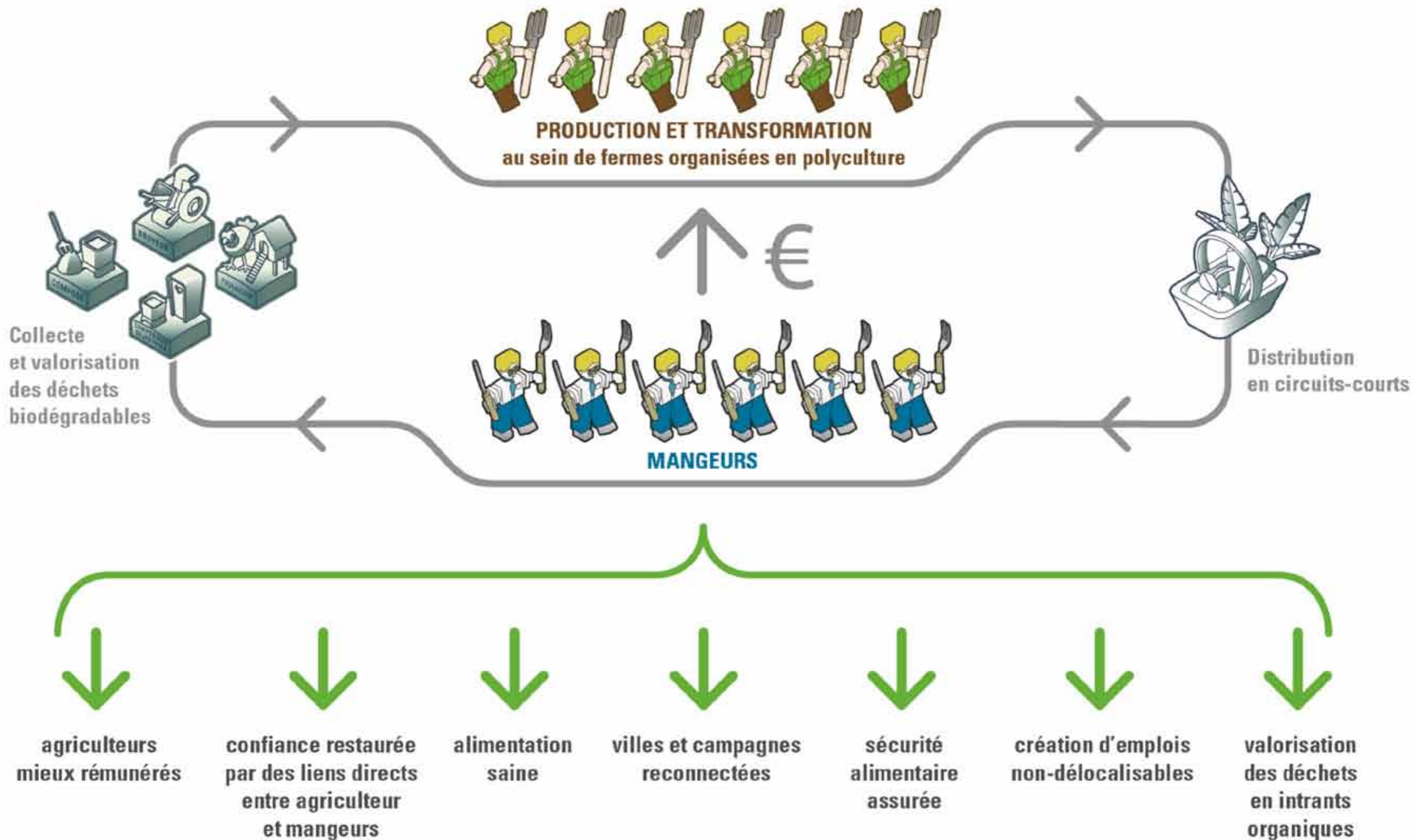

CAMPAGNE

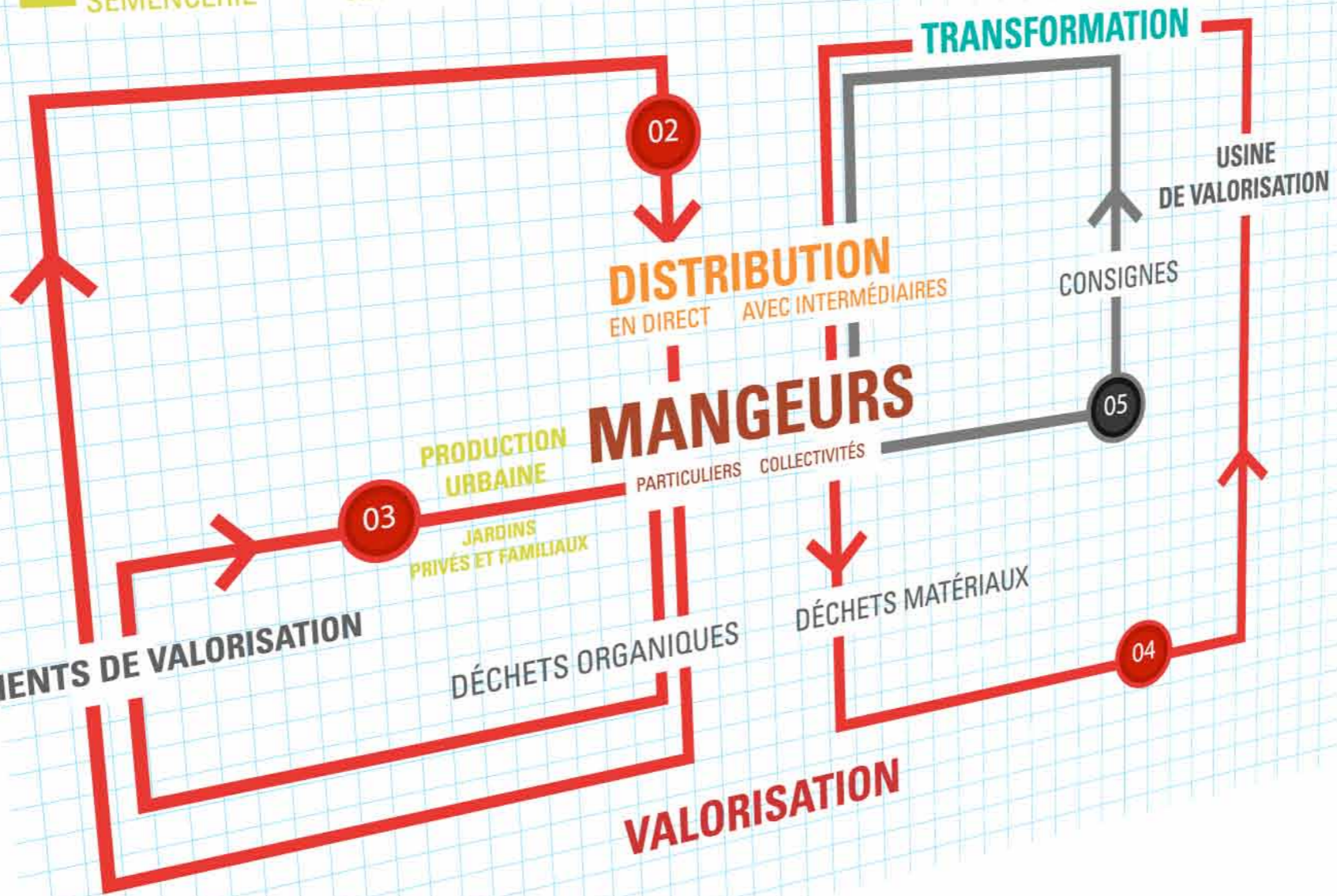

VILLE

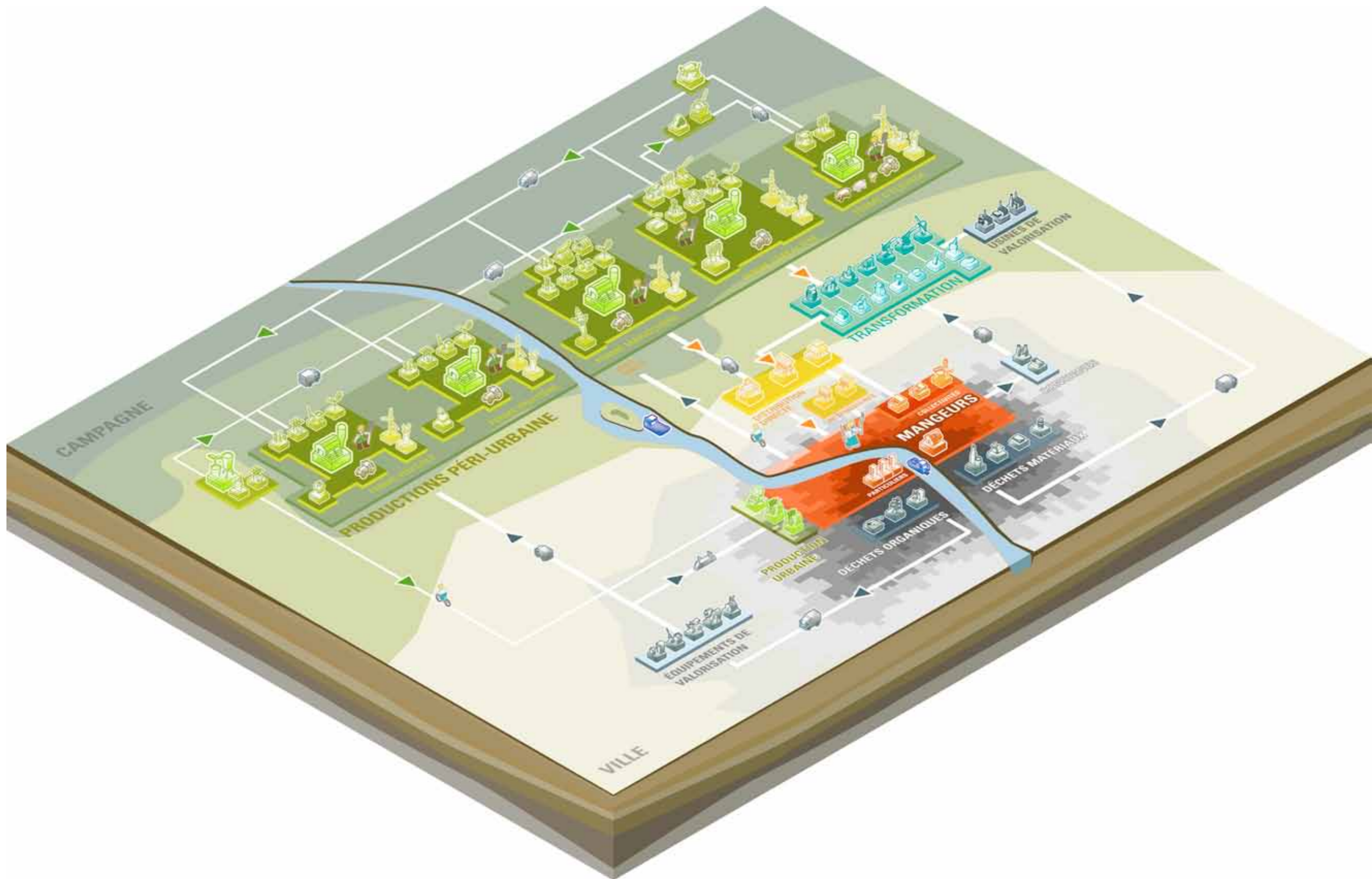







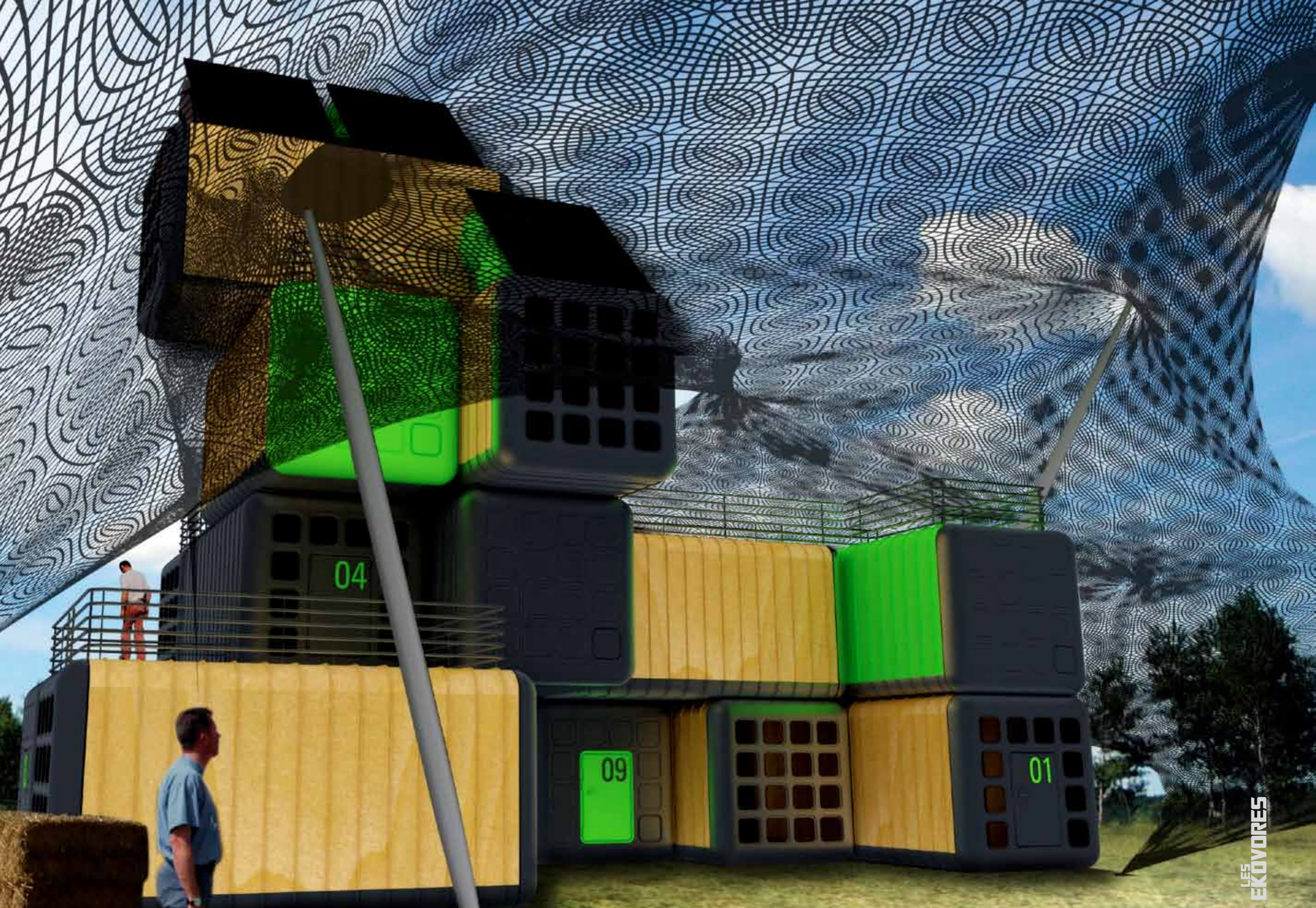

LES  
EKOVOIRES

\_ CULTIVER EN CEINTURE ALIMENT-TERRE

FERMES D'URGENCE

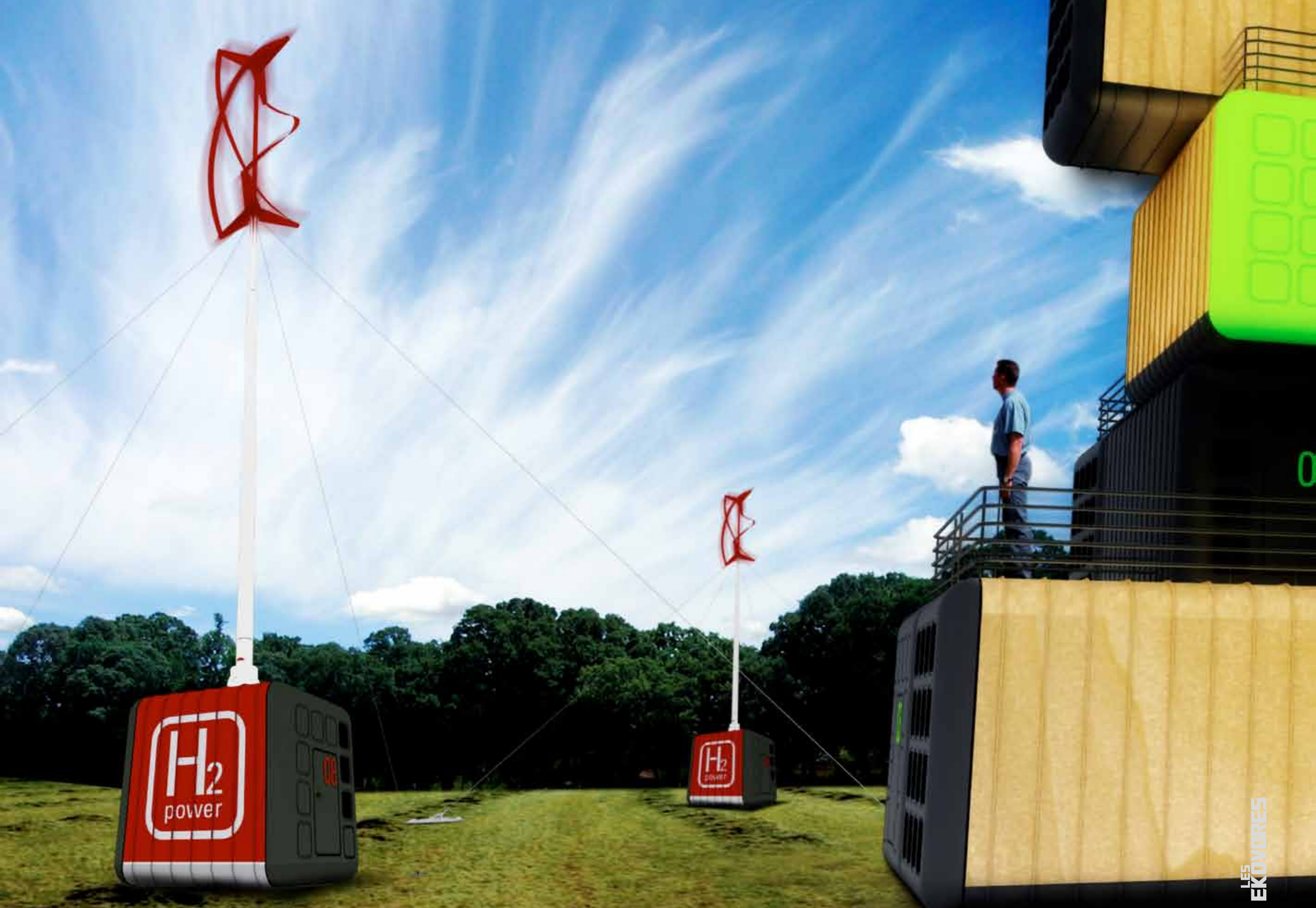

LES  
ÉKOVOIRES

\_ CULTIVER EN CEINTURE ALIMENT-TERRE

FERMES D'URGENCE - ÉOLIENNES



LES  
EKOVORES

\_ CULTIVER EN CEINTURE ALIMENT-TERRE

FERMES D'URGENCE - LE POULAILLER



LES  
EKOVOIRES

\_ CULTIVER EN CEINTURE ALIMENT-TERRE

FERMES D'URGENCE - SERRES



LES  
ÉKOVORES

\_ CULTIVER EN VILLE

BARGES POTAGÈRES



LES  
ÉKOVOIRES

\_ CULTIVER EN VILLE

POTAGERS EN PIED D'IMMEUBLE



LES  
ÉKOVOIRES





LES  
ÉKOVORES

\_ CULTIVER EN VILLE

POTAGER TOITURE



LES  
EKOVORES

\_ CULTIVER EN VILLE

RUCHERS SUR PILOTIS



LES  
ÉKOVORES

\_ CULTIVER EN VILLE

SERRE VÉLO-ROUTIÈRE



LES  
ÉKOVORES

\_ CULTIVER EN VILLE

SERRE VÉLO-ROUTIÈRE



LES  
EKO  
VOKES

\_DISTRIBUER

BATEAU-MARCHÉ



LES  
ÉKOVORES

\_DISTRIBUER

BATEAU-MARCHÉ



\_DISTRIBUER

TRAM-TRAIN MARCHÉ

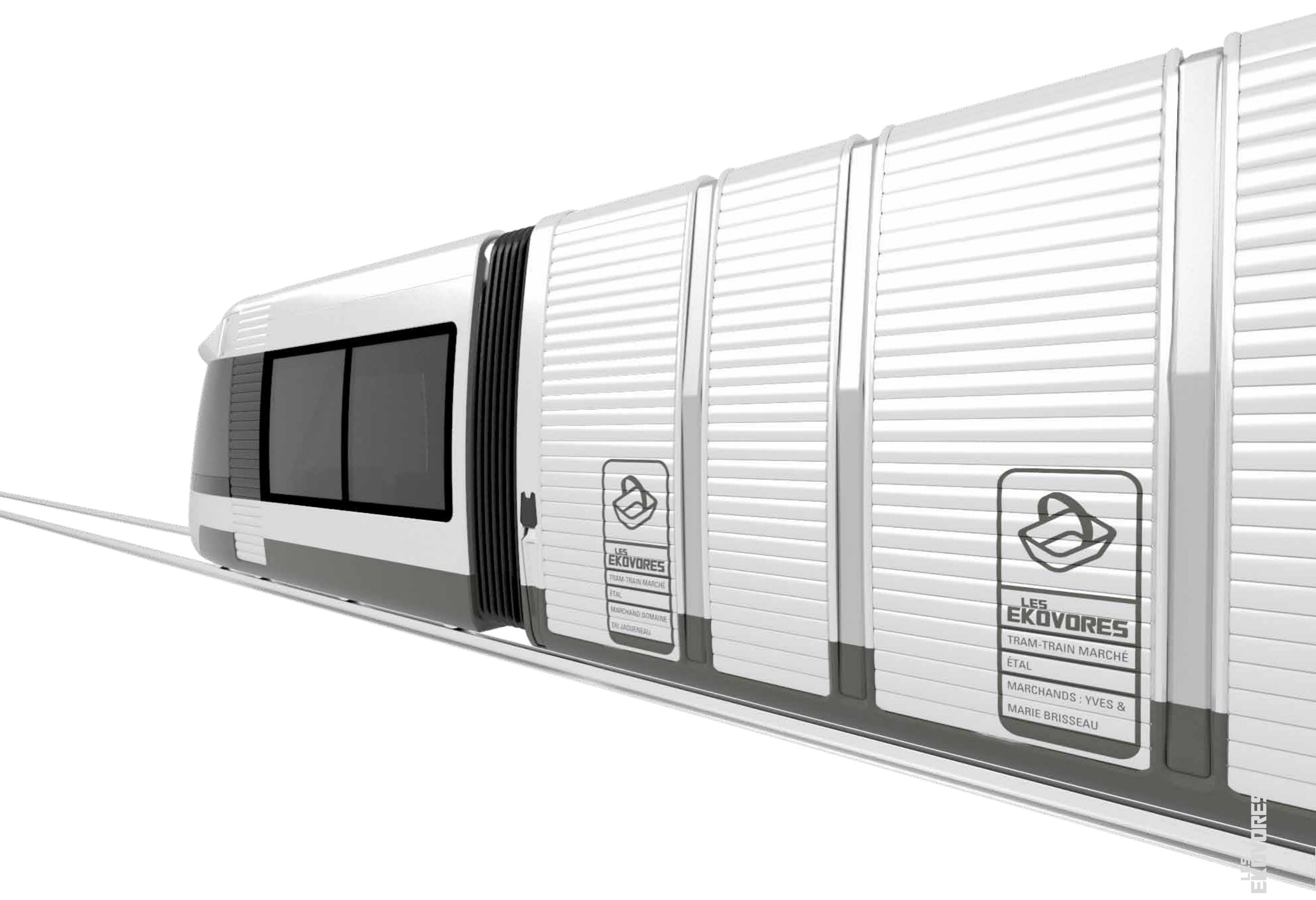

\_DISTRIBUER

TRAM-TRAIN MARCHÉ



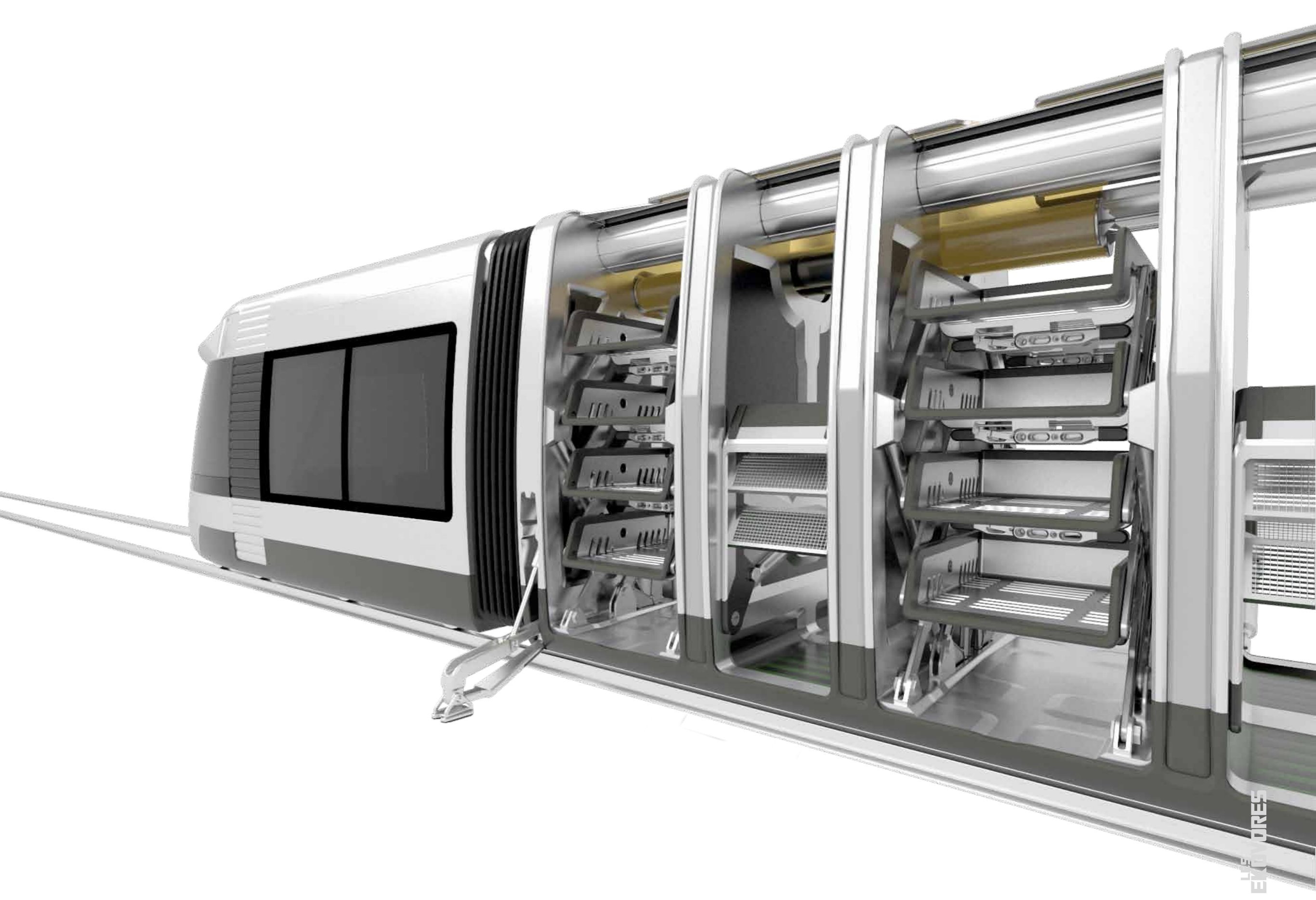

EVADORES

\_DISTRIBUER

TRAM-TRAIN MARCHÉ

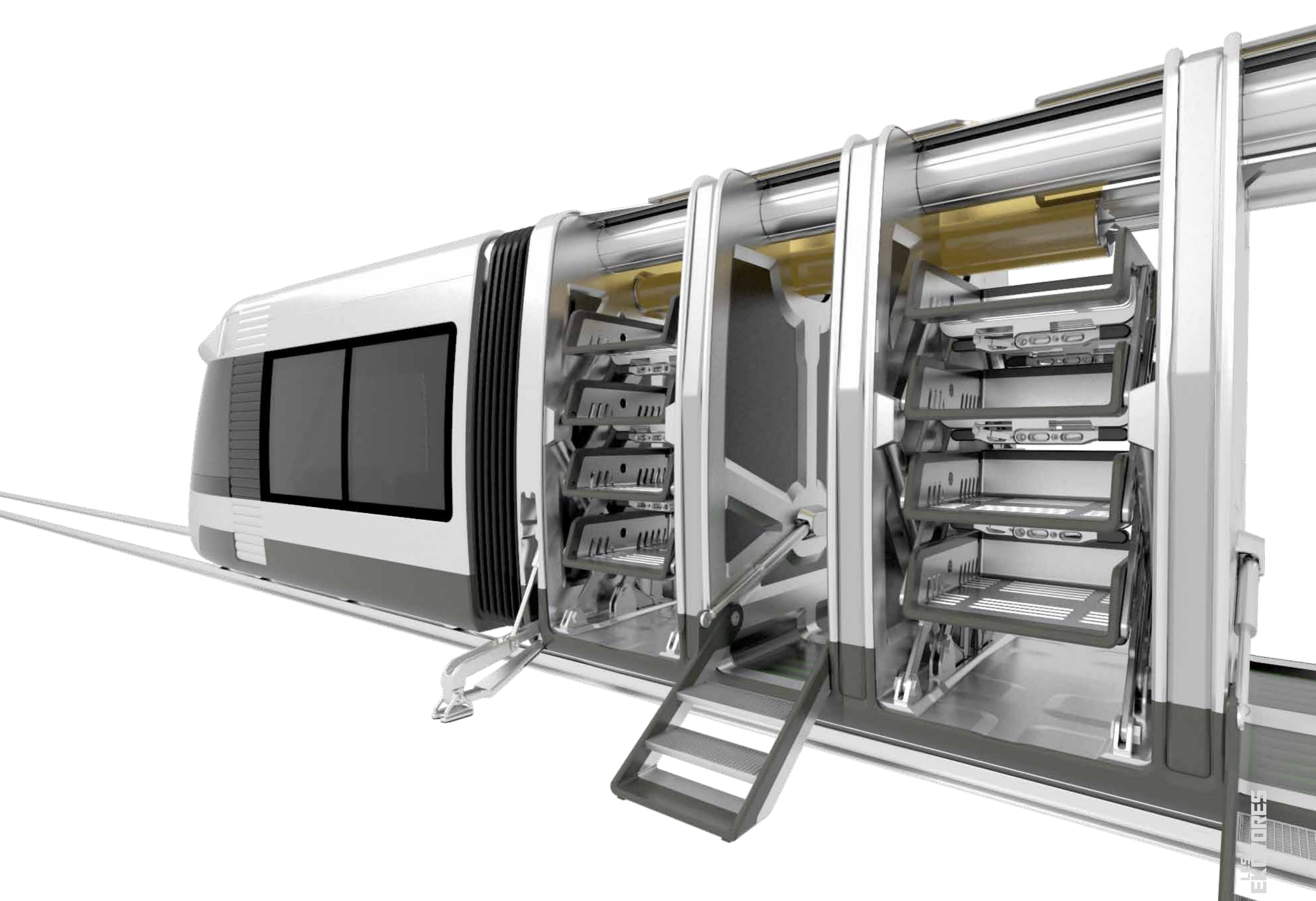

LES  
BORES

\_DISTRIBUER

TRAM-TRAIN MARCHÉ

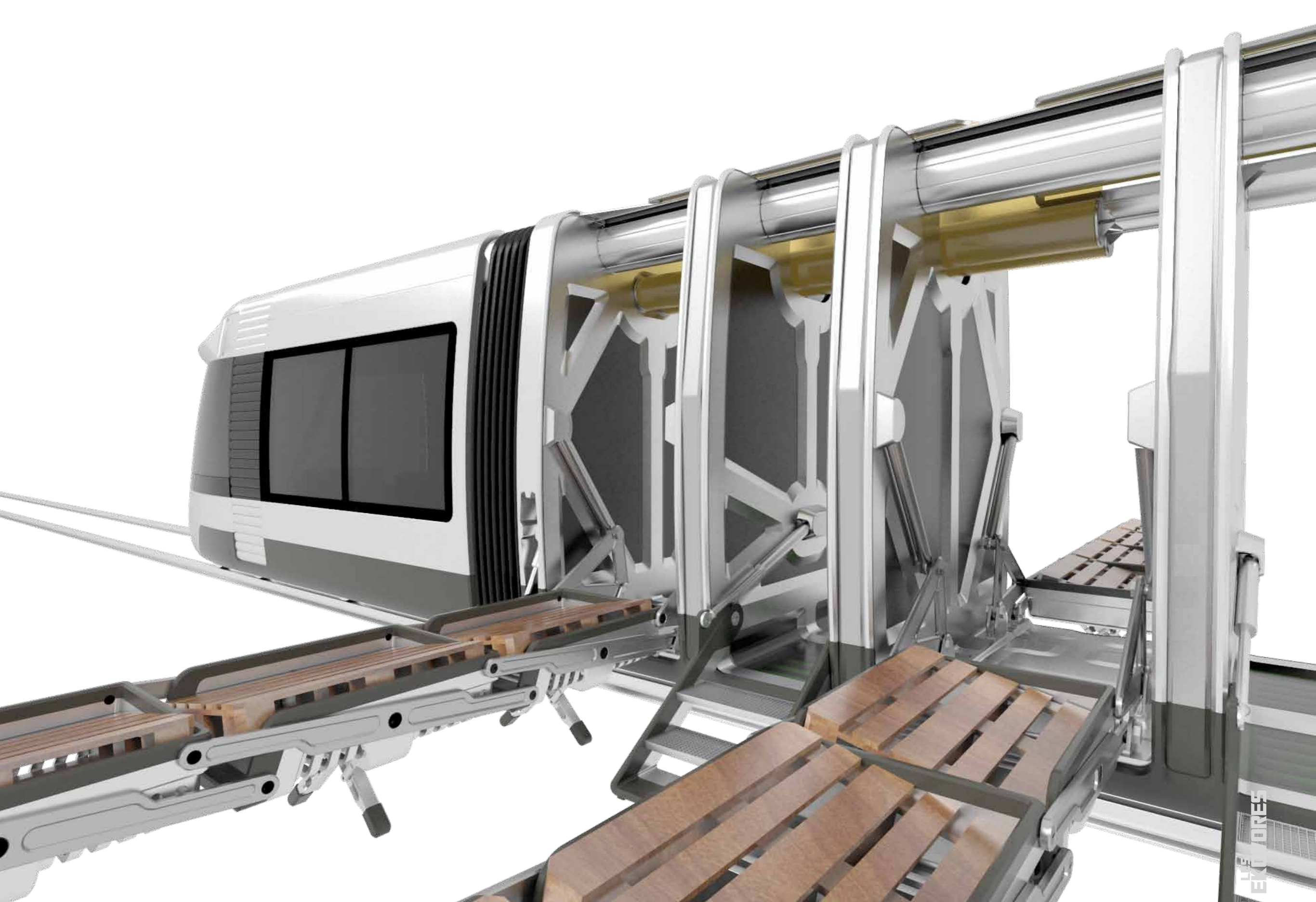

EVOLUORES

\_DISTRIBUER

TRAM-TRAIN MARCHÉ

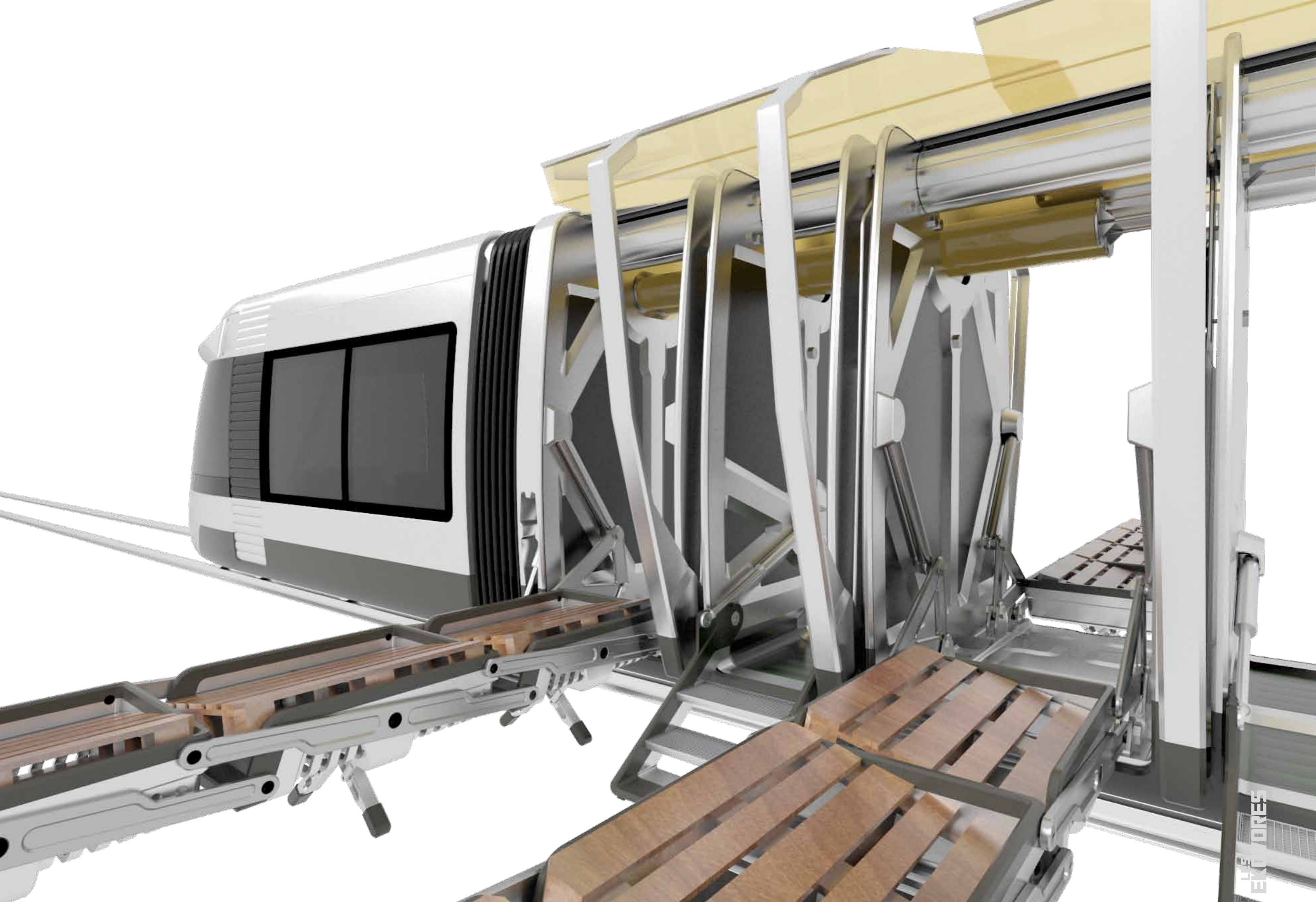

EVOLORES

\_DISTRIBUER

TRAM-TRAIN MARCHÉ

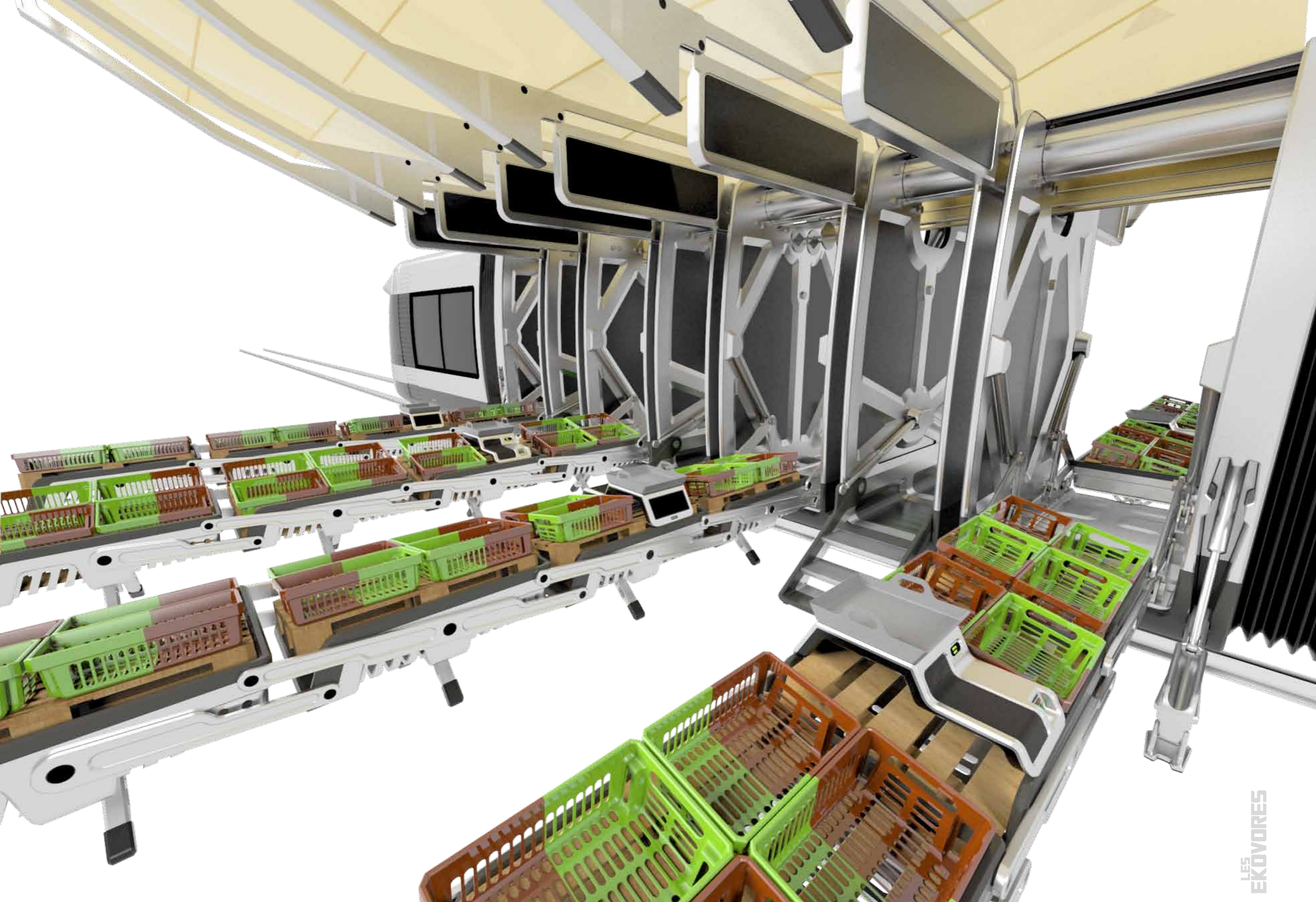

LES  
EKOVORES

\_DISTRIBUER

TRAM-TRAIN MARCHÉ



LES  
EKOVORES

\_DISTRIBUER

REMORQUE AMAP



LES  
EKOVOIRÉS

\_ TRANSFORMER

CONSERVERIE DE QUARTIER



LES  
LÉGUMIÈRES

\_ TRANSFORMER

LÉGUMERIE D'ÉCOLE



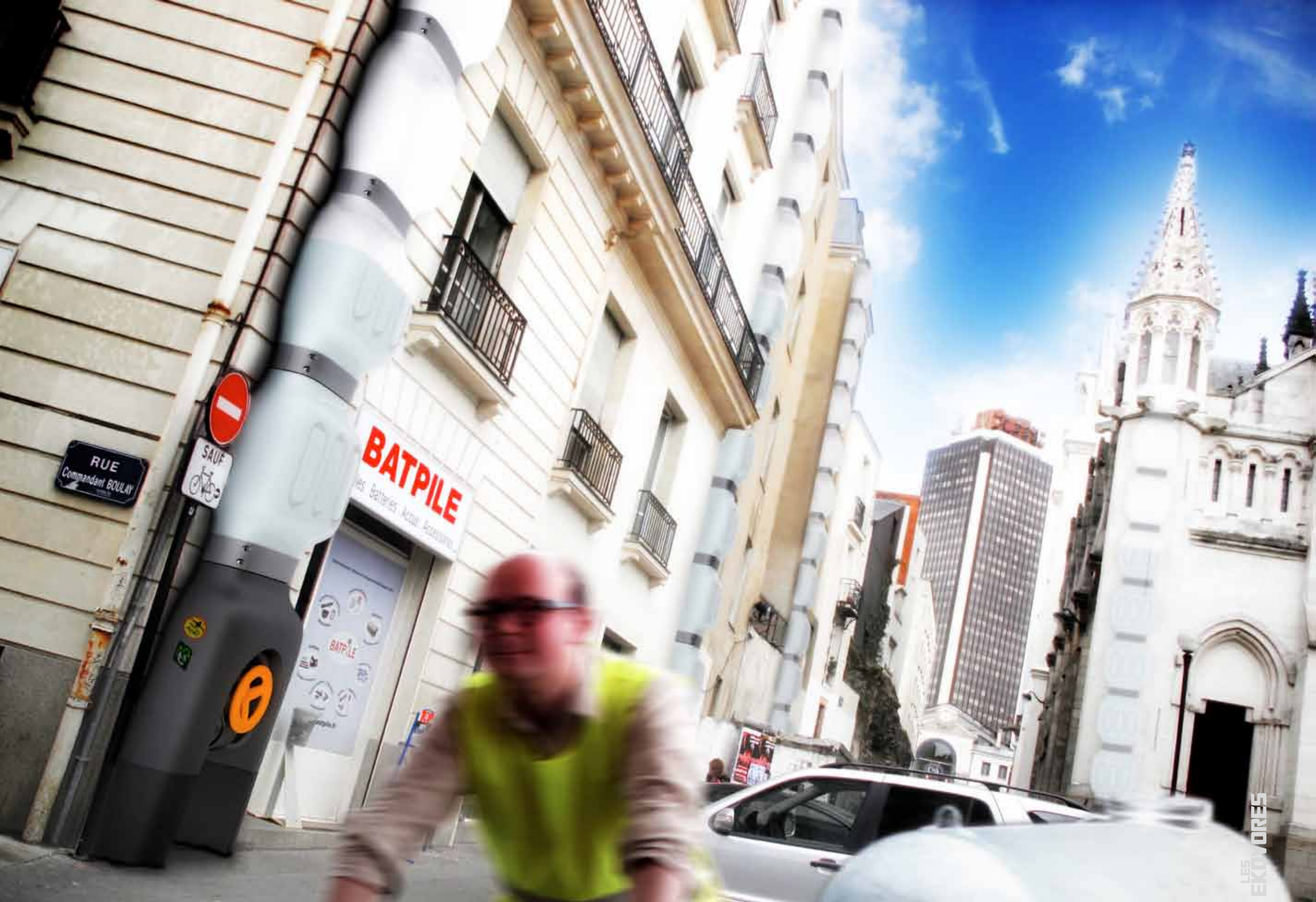

LES  
EKOVORES

\_ VALORISER

RÉSERVOIR D'EAU PLUVIALE





LES  
EKOVORES

\_ VALORISER

TOILETTES SÉCHES PUBLIQUES

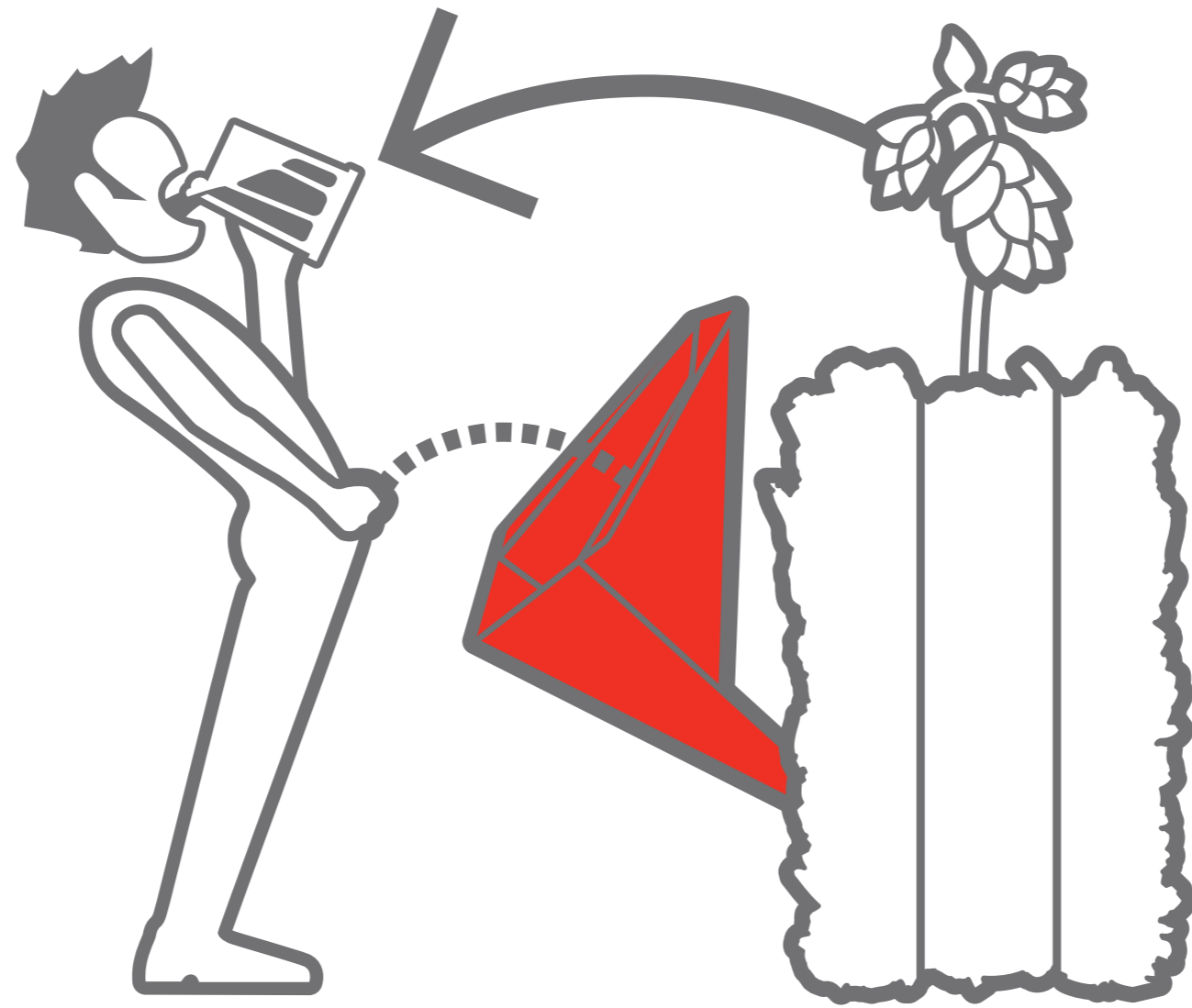

# L'URITONNOIR

l'urinoir sec

[uritonnoir.com](http://uritonnoir.com)

LES  
EKOVORES

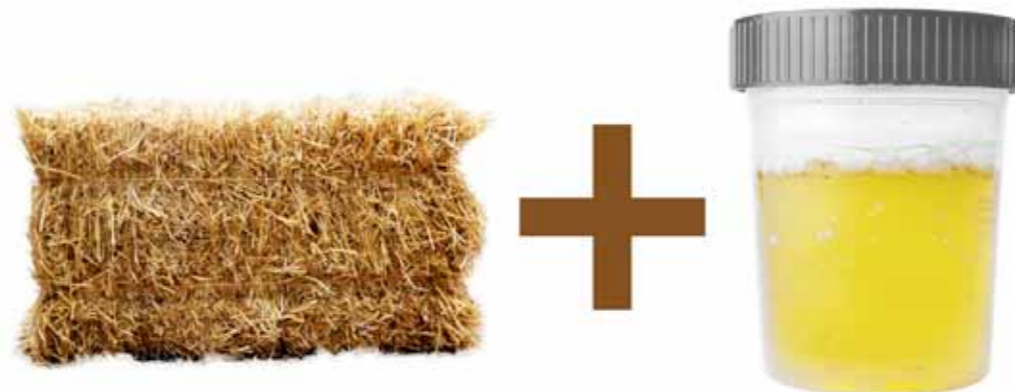

**paille**  
(Carbone)

**urine**  
(Azote)



6 mois plus tard



**compost**



LES  
ÉCOYDRES

\_ VALORISER

URINOIR SEC



LES ÉKOVOIRES

\_ VALORISER

URINOIR SEC



LES  
ÉKOVORES

\_ VALORISER

COMPOSTEUR PARTAGÉ





LES  
EKOVORES

\_ VALORISER

COMPOSTEUR PARTAGÉ



LES  
ÉKOYDRES

\_ VALORISER

COMPOSTEUR PARTAGÉ



LES  
ÉKOVOIRÉS

\_ VALORISER

COMPOSTEUR PARTAGÉ







LES  
ÉKOVOIRES

\_ VALORISER

COMPOSTEUR PARTAGÉ









## LES EKOVORES LES CONCEPTEURS

Le composteur Ekovore est conçu, développé et commercialisé par l'agence de design Faltazi. [www.ekovore.com](http://www.ekovore.com)



## LES IMPULSEURS

Idéelles est un collectif d'habitantes de Malakoff Pré-Gauchet, actrices de la transformation de leur environnement, elles impulsent des projets d'habitants tel que ce composteur pour se réapproprier l'espace public par l'aménagement d'équipements durables et créateurs de liens sociaux. [tiny.cc/ideelles](http://tiny.cc/ideelles)



## LES CONSTRUCTEURS

ATAO est une association qui porte 7 chantiers d'insertion. Ce composteur est l'œuvre du chantier métallerie qui emploie 13 personnes en contrat d'insertion.

[www.atao-insertion.org](http://www.atao-insertion.org)



## LES MAÎTRES-COMPOSTEURS

Compostri est une association qui accompagne les habitants et les établissements scolaires dans la mise en place de projets de compostage à l'échelle d'un quartier, immeuble, jardins collectifs, écoles... Avec le composteur Ekovore, Compostri fait la preuve que de tels projets peuvent voir le jour partout en ville, en proposant une parfaite intégration à l'espace urbain et en fournissant un espace de convivialité mis à disposition des habitants. [www.compostri.fr](http://www.compostri.fr)

## LES ÉCOCITOYENS DU QUARTIER MALAKOFF

Soucieux de mieux trier leurs déchets et de les valoriser en compost, ces habitants ont choisi de se regrouper autour de ce composteur et organisent toutes les semaines des rendez-vous-compost. [compost.malakoff@compostri.fr](mailto:compost.malakoff@compostri.fr)



## LES JARDINIERS DU SEVE

Ces grands connaisseurs de la nature en ville savent avec précision choisir les meilleures espèces de fruitiers et graminées pour habiller le toit du composteur. [www.jardins.nantes.fr](http://www.jardins.nantes.fr)



## LES SOUTIENS FINANCIERS

En toute cohérence avec leur politique de prévention et de réduction des déchets, la métropole et l'Ademe soutiennent cette démarche innovante de construction d'un prototype de composteur de seconde génération.

[www.ademe.fr](http://www.ademe.fr)

[www.nantesmetropole.fr](http://www.nantesmetropole.fr)

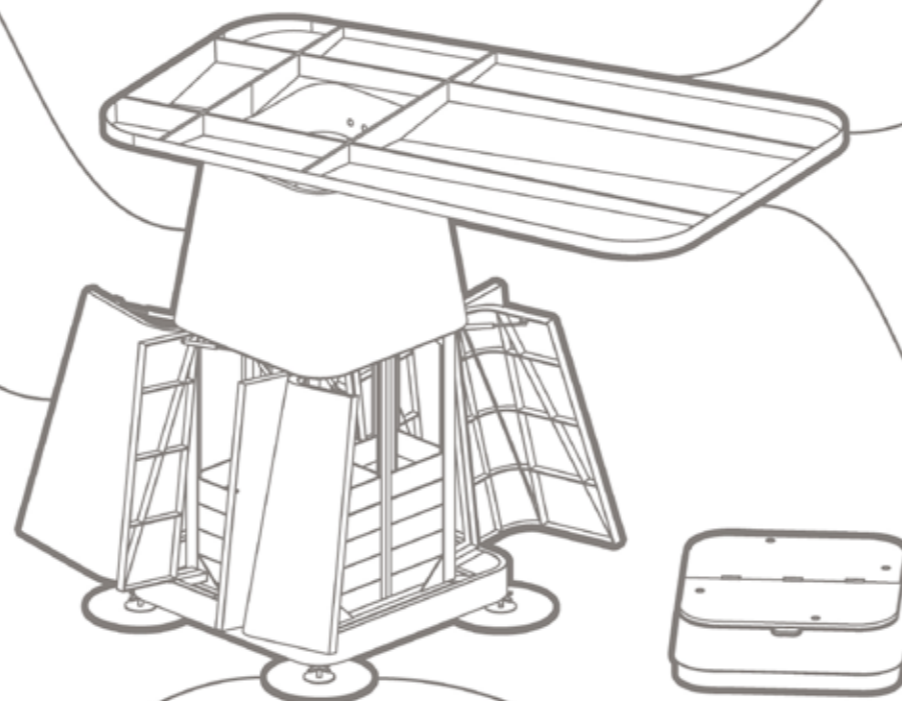

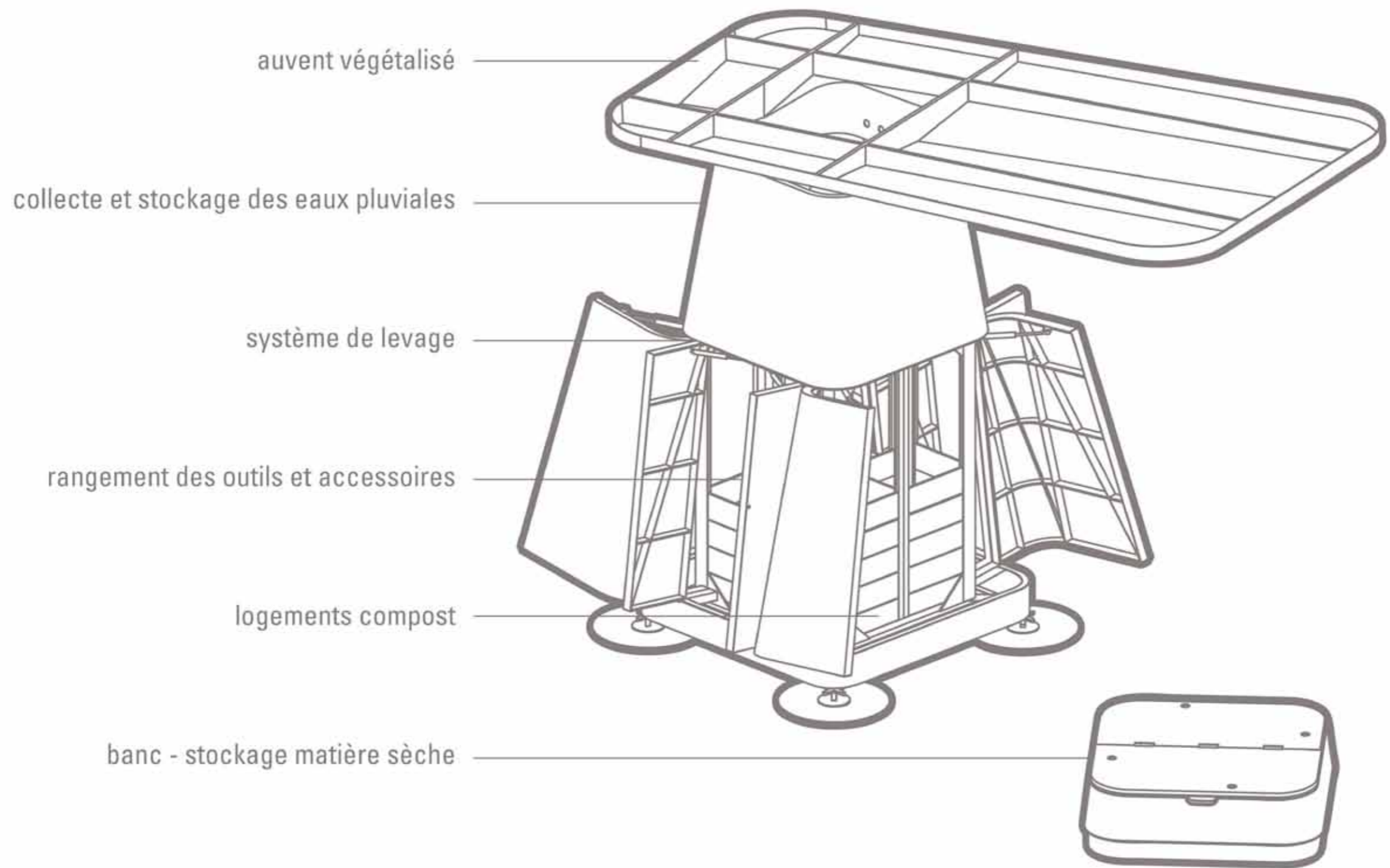

auvent végétalisé

collecte et stockage des eaux pluviales

système de levage

rangement des outils et accessoires

logements compost

banc - stockage matière sèche

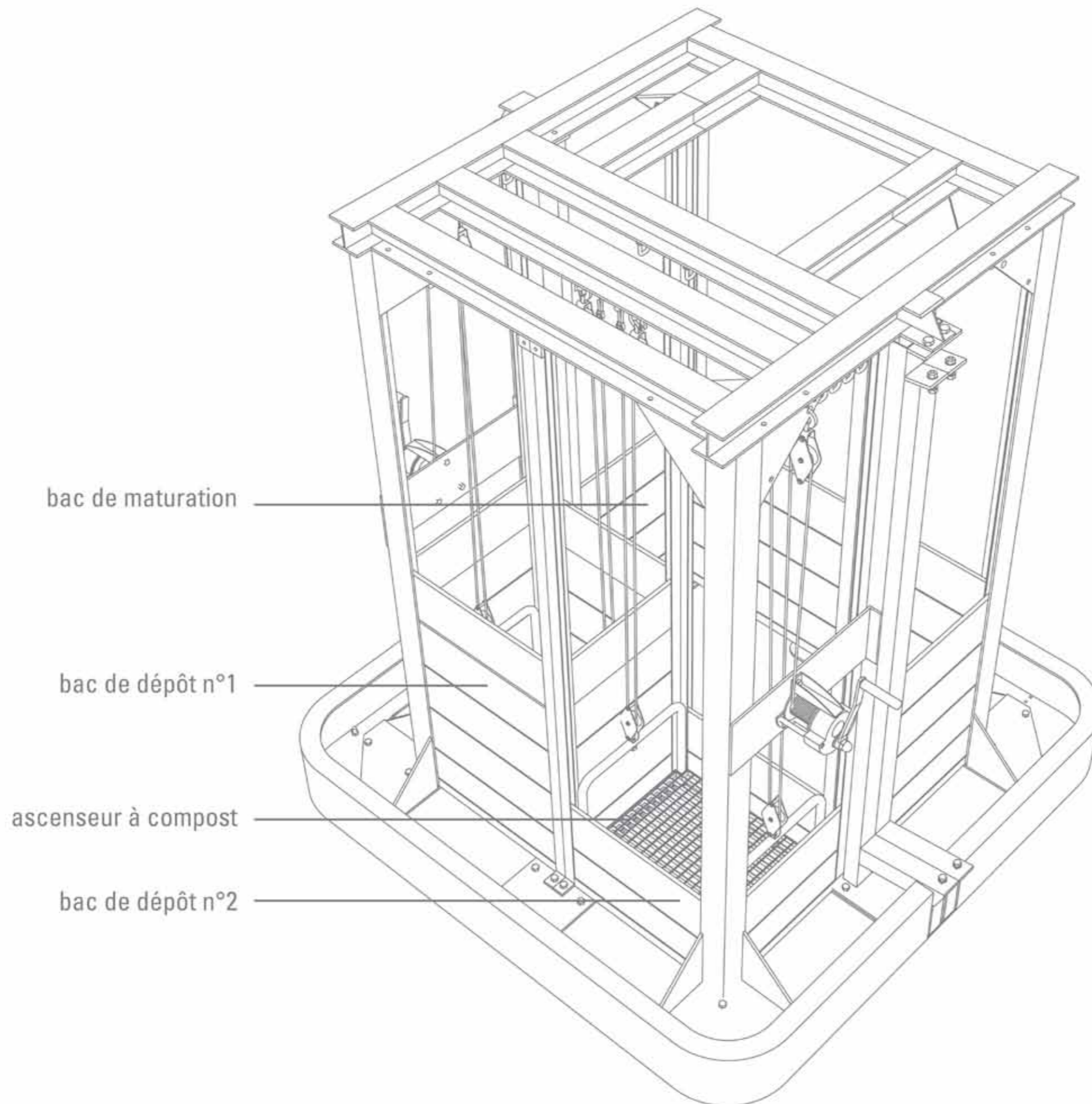

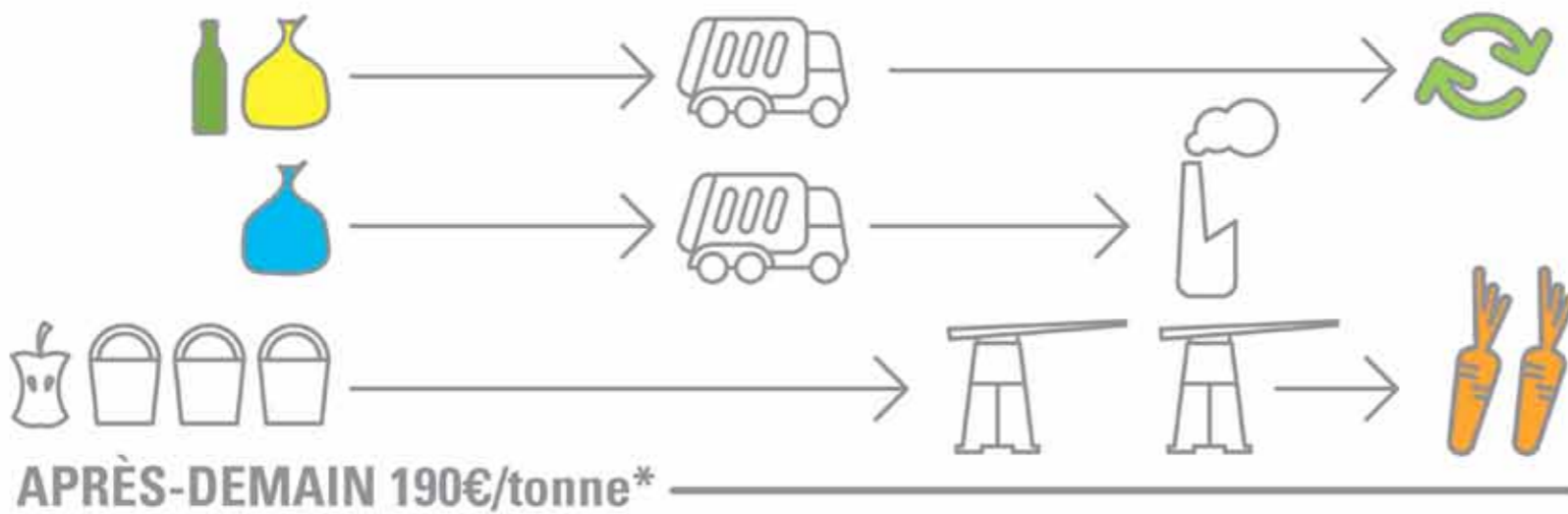
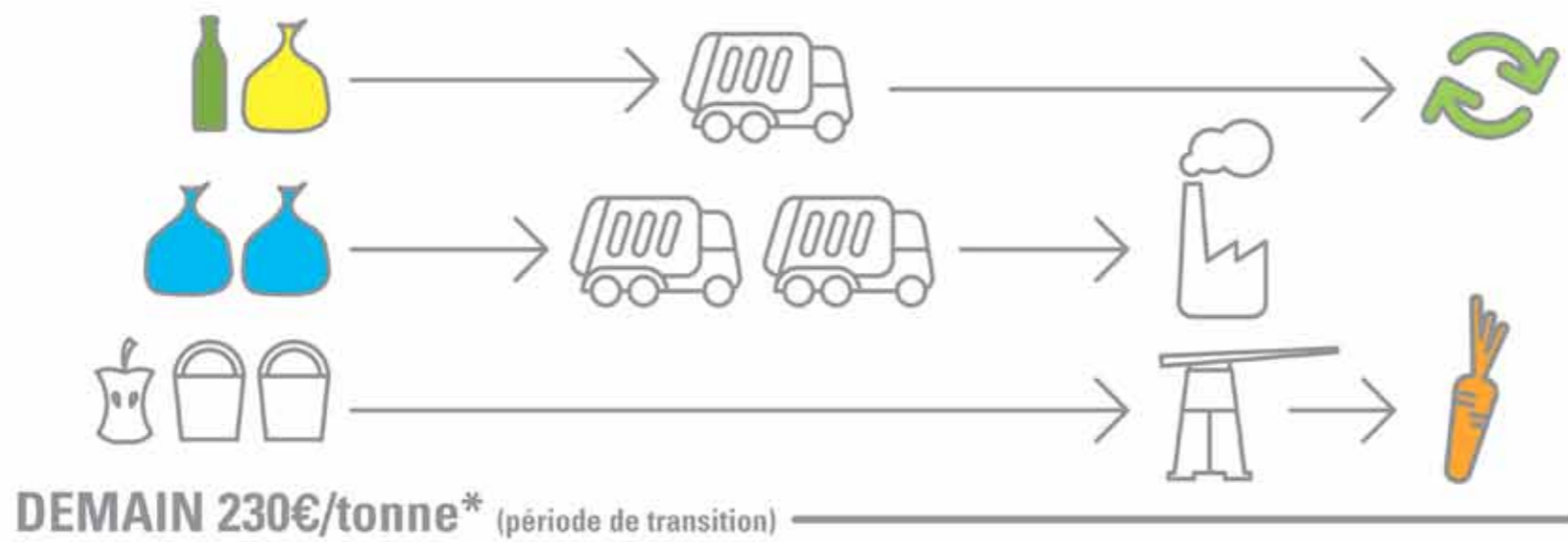
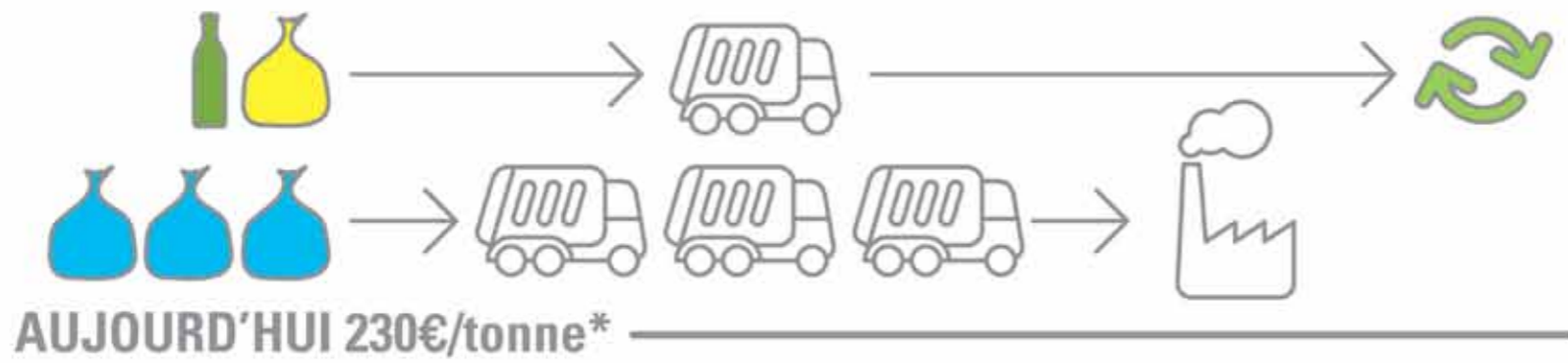

\* prix moyen du traitement des déchets

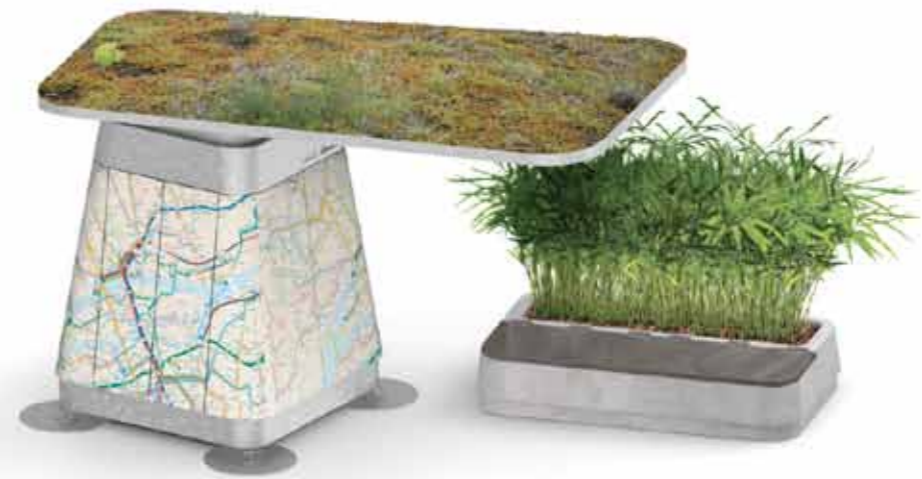

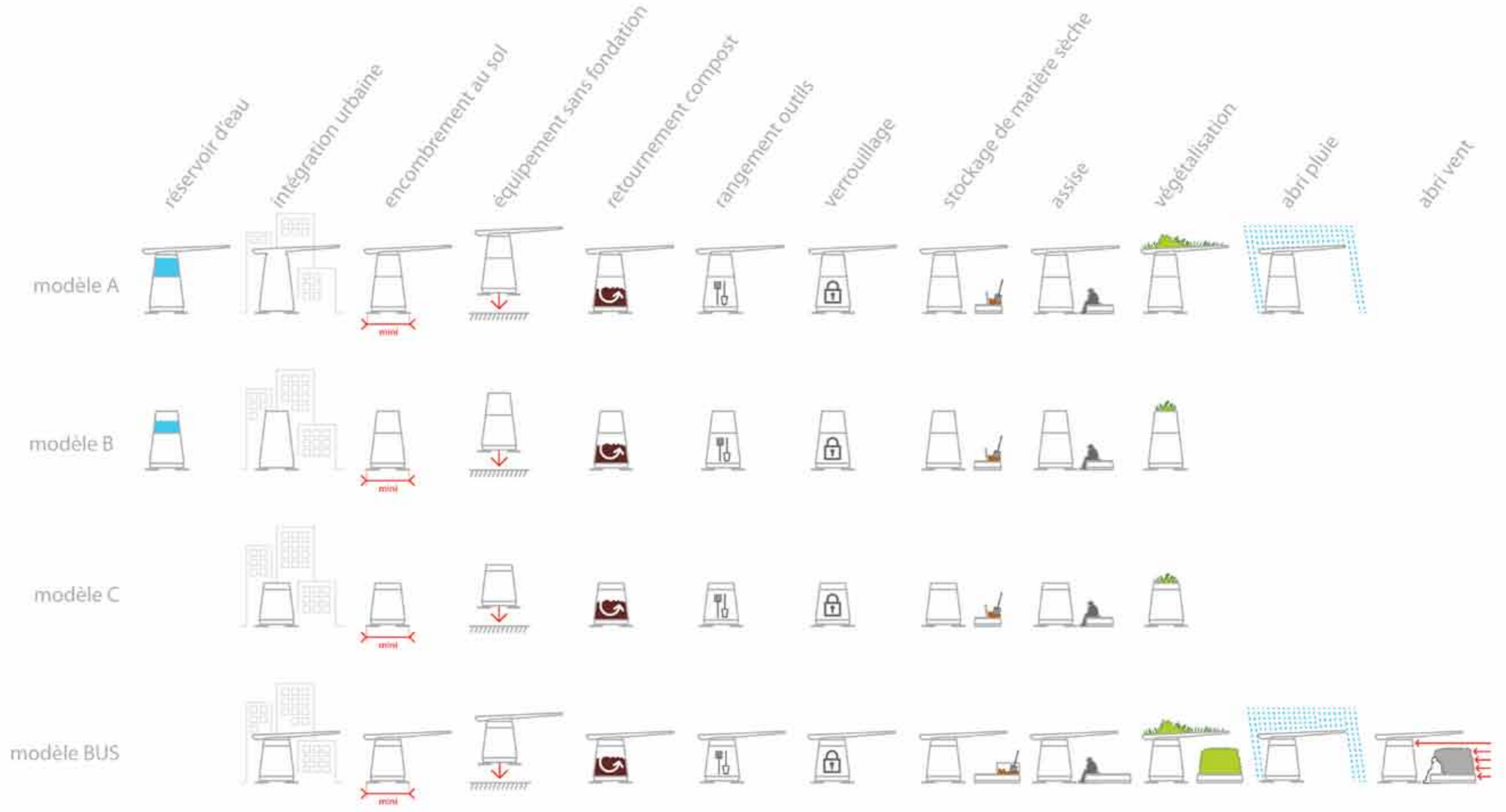

# LES MÉTIERS EKOVORES



LES IMPULSEURS

---



LES FRUCTIFIEURS

---



LES MARMITONS

---



LES ÉRUDITS

---



LES DISCRETS

---



LES TRANSMUTATEURS

---



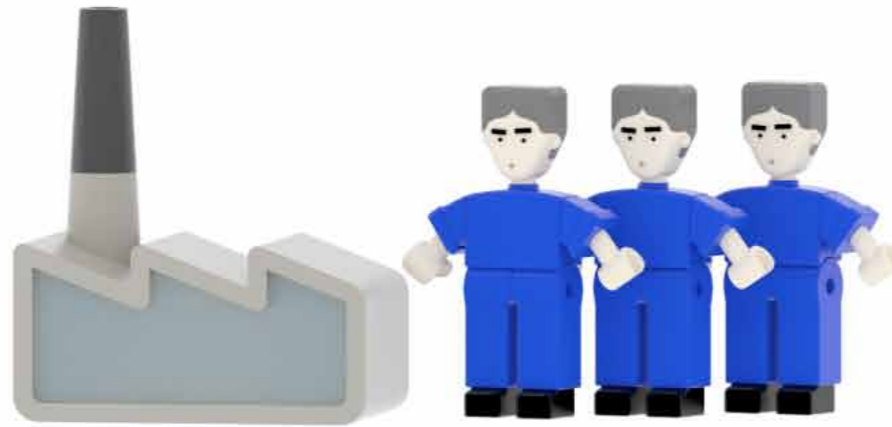

FABRICATION LOCALE DES ÉQUIPEMENTS  
**L'ACTIVITÉ ARTISANALE**



CRÉATION D'EMPLOIS LOCAUX  
DÉDIÉS À L'ANIMATION DES ÉQUIPEMENTS  
**L'EMPLOI**

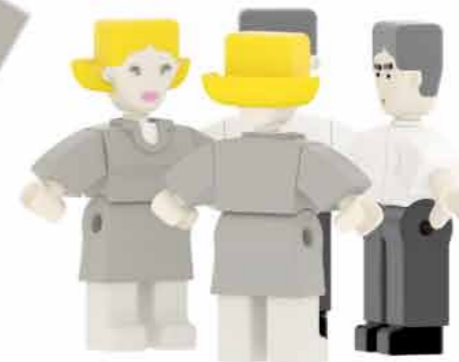

LIEU D'ÉCHANGES AU SEIN D'UN QUARTIER  
**LE LIEN SOCIAL**

[facebook.com/lesekovores](https://facebook.com/lesekovores)

[lesekovores.com](https://lesekovores.com)